

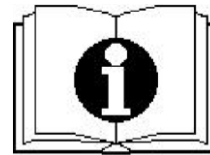

装配示意图



手推式洗地机 T35B-PLUS

ScrubberDryer T35B-PLUS



目 录

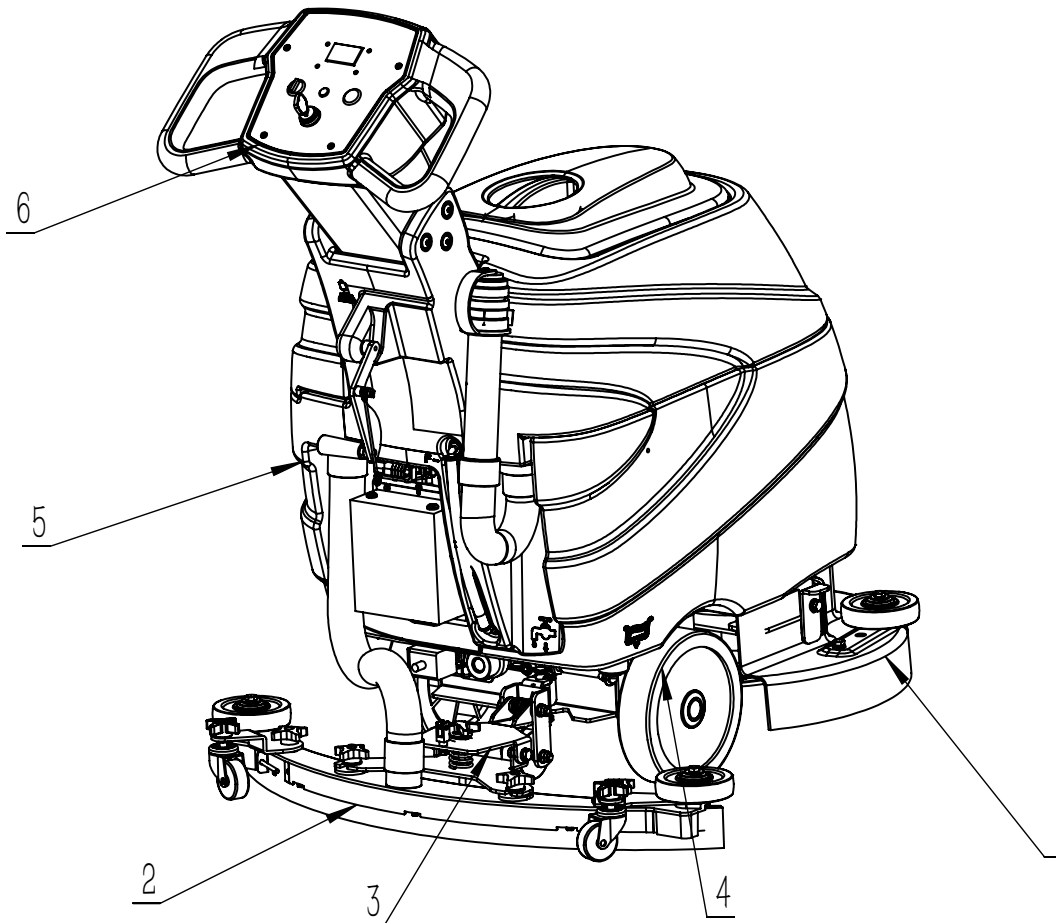

1.	机头组件.....	3—4
	NOSE ASSEMBLY	
2.	扒头组件.....	5—6
	SQUEEGEE ASSEMBLY	
3.	扒头支架组件.....	7—8
	SQUEEGEE CONTROL ASSEMBLY	
4.	底座架组件.....	9—11
	FRAME ASSEMBLY	
5.	水箱组件.....	12—17
	WATER TANK ASEEMBLY	
6.	控制面板组件.....	18—19
	CONTROL PANEL ASSEMBLY	
7.	控制面板组件(EU).....	20—21
	CONTROL PANEL ASSEMBLY(EU)	
8.	机头安装小组件.....	22—23
	HEAD MOUNTING PANEL	
9.	底座架安装小组件.....	24—25
	FRAME ASSEMBLY	
10.	扒头支架安装小组件.....	26—27
	SQUEEGEE CONTROL ASSEMBLY	
11.	包装组件.....	28
	PACKAGING COMPONENTS	
12.	定制包.....	29
	CUSTOM PACKAGE	
13.	选配包.....	30
	OPTIONAL PACK	

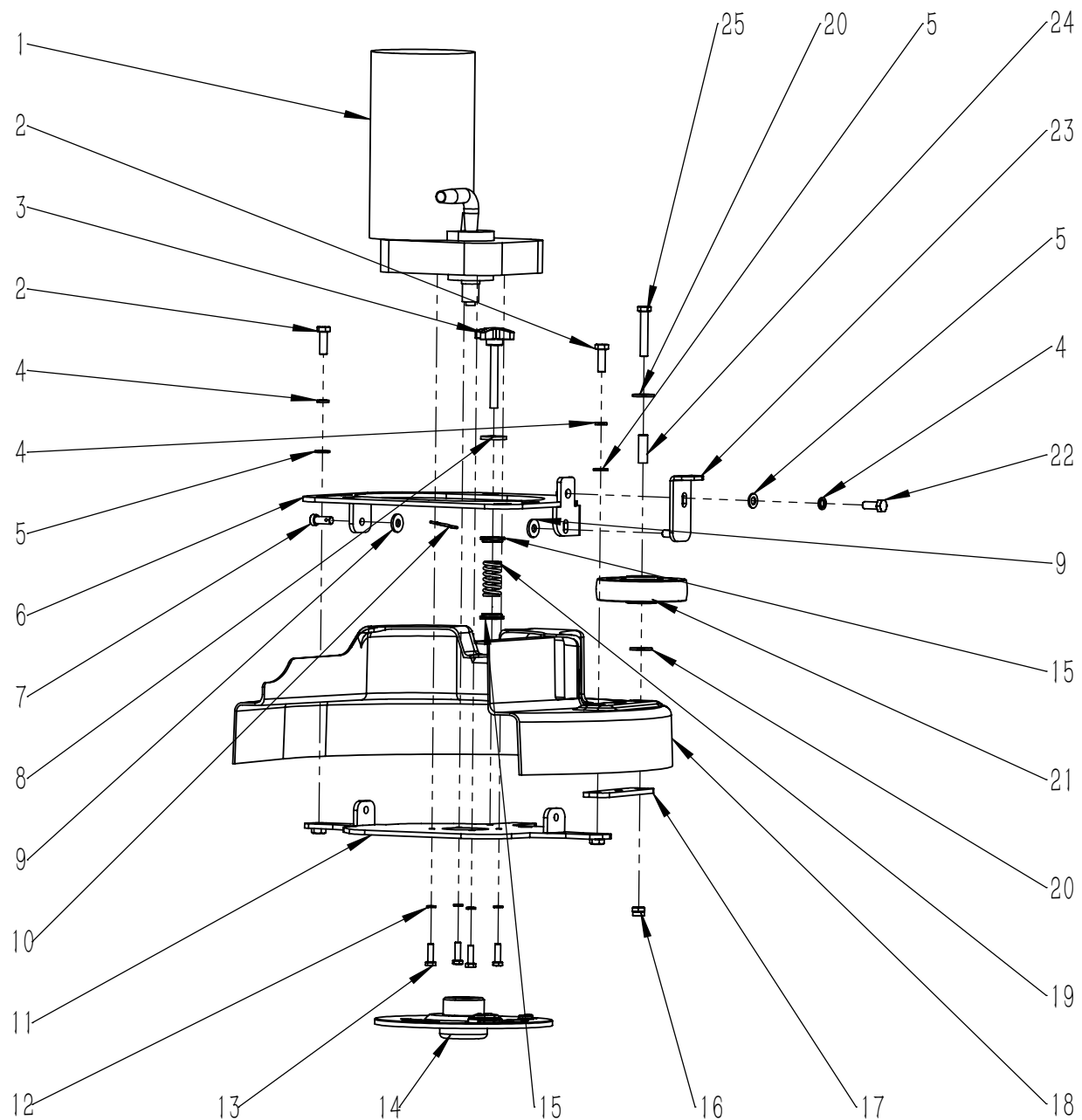

项目号 ITEM	零件号 P/N	数量 QTY	名称	DESCRIPTION
1	W020240	1	刷盘电机组件-24V-500W-140RPM	BRUSH MOTOR ASSEMBLY 24V 500W 140 RPM
2	N010094	2	外六角-M8x25-不锈钢	SCREW M8x25 A2
3	N100037	1	调节手柄 M8x70	ADJUSTER ME _x 70
4	N040017	3	弹垫-M8-不锈钢	LOCK WASHER M8
5	N030010	3	平垫-8x16x1.6-不锈钢	WASHER 8x16x1.6 A2
6	A040058	1	机头上安装板 285x242	NOSE MOUNTING PLATE UP 285 x 242
7	B060123	1	机头安装销 D8x25	MOUNTING PIN Φ8 x 25
8	N030035	1	平垫-8x28x3-不锈钢	WASHER 8x28x3 A2
9	B050058	2	四氟垫片 D8.2xD20x2.5	WASHER Φ8.2xΦ20x2.5
10	N100035	1	R型弹簧插销 D2x40	BOLT TYPE R
11	A040059	1	机头下安装板 393x280	NOSE MOUNTING PLATE DOWN 393x280
12	N040001	4	弹垫-M6-镀锌	LOCK WASHER M6 ZINC
13	N010006	4	外六角-M6x20-镀锌	SCREW M6x20 ZINC
14	W020077	1	刷盘锁紧器组件-左	LOCKER ASSEMBLY-LEFT
15	B060121	2	压簧挡圈	SPRING SEEGER RING
16	N020024	1	自锁螺母-M8-不锈钢	LOCK NUT M8 A2
17	A040056	1	防撞轮安装板	WHEEL MOUNTING PLATE
18	C010220	1	机头外罩-T35-19”	COVER T35 BLACK
19	B070026	1	压簧 D2.8xD20x38 (7圈)	SPRING Φ2.8xΦ20x38
20	N030028	2	平垫-8x24x2-不锈钢	WASHER 8x24x2 A2
21	N110019	1	防撞轮 D100x29.5	WHEEL Φ100x29.5
22	N010142	1	外六角-M8x20-不锈钢	SCREW M8x20 A2
23	A040057	1	机头侧支架	SUPPORT
24	B020027	1	防撞轮铜套 8x10x31	BUSHING 8 x10x 31
25	N010144	1	外六角-M8x50-不锈钢	SCREW M8x50 A2

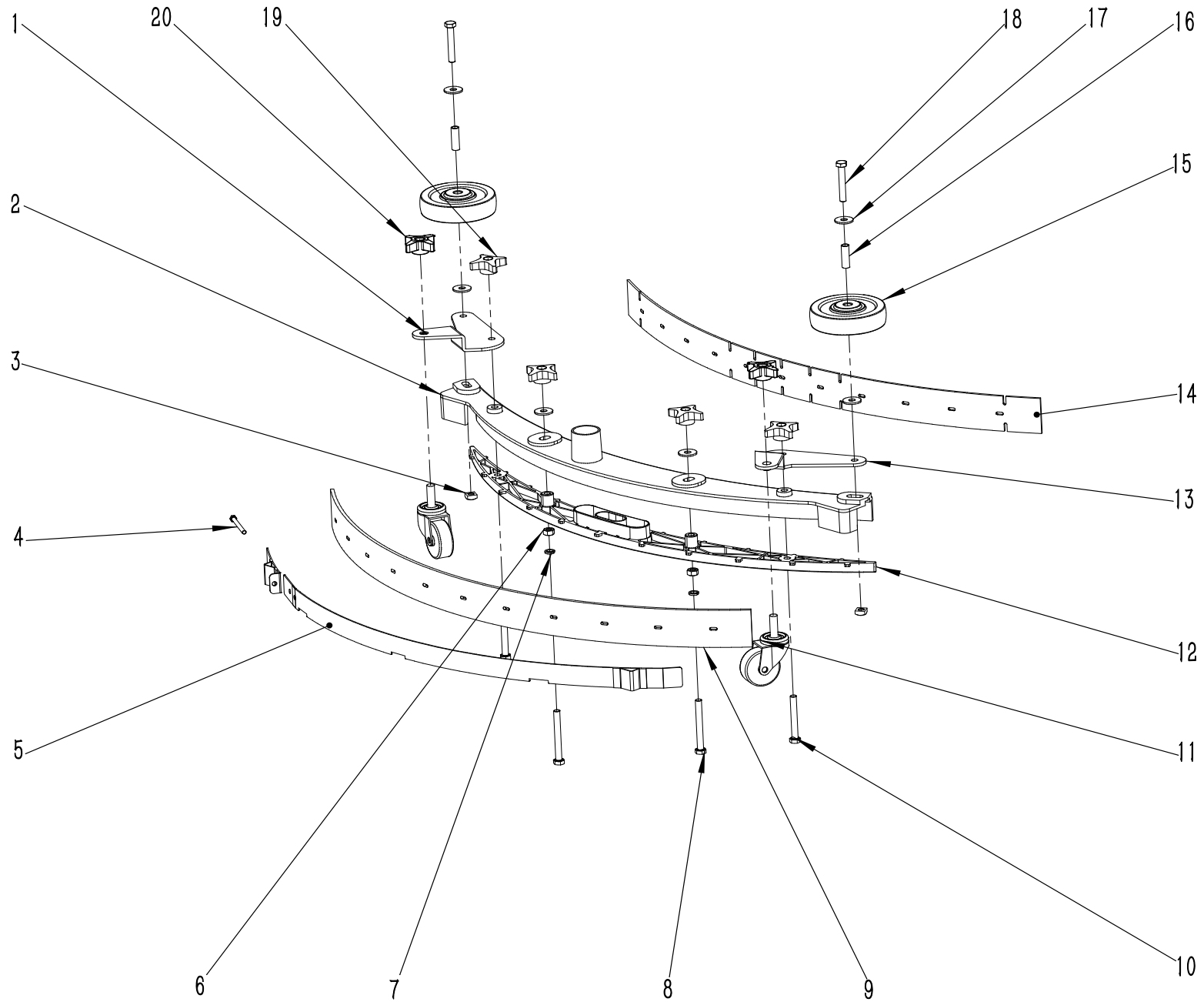

项目号 ITEM	零件号 P/N	数量 QTY	名称	DESCRIPTION
1	A030105	1	万向轮支架右 760 新	SUPPORT RIGHT 760 NEW
2	D010042	1	扒头主体 760 新	SQUEEGEE BODY 760 NEW
3	N020011	2	方形螺母-M8-13x13x6.5-不锈钢	NUT M8 13x13x6.5 A2
4	N010146	1	外六角-M5x55-不锈钢	SCREW M5x55 A2
5	A030035	1	扒头后固定钢板 820	PLATES 820
6	N020010	4	螺母-M8-不锈钢	NUT M8 A2
7	N040017	2	弹垫-M8-不锈钢	LOCK WASHER M8
8	N010127	2	外六角-M8x70-不锈钢-全牙	SCREW M8x70 A2
9	C030039	1	后刮条天然橡胶 4x53x835	REAR SQUEEGE BLADE RUBBER4x53x835
10	N010128	2	外六角-M8x60-不锈钢	SCREW M8x60 A2
11	N110048	2	M10 螺杆万向轮 Φ50	M10 SCREW UNIVERSAL WHEEL Φ50
12	B050069	1	半月板 760 新	PLATE 760 NEW
13	A030104	1	万向轮支架左 760 新	SUPPORT LEFT 760 NEW
14	C030038	1	前刮条天然橡胶 3x50x785	FRONT SQUEEGE BLADE RUBBER3x50x785
15	N110019	2	防撞轮 D100x29.5	WHEEL Φ100x29.5
16	B020027	2	防撞轮铜套 8x10x31	BUSHING 8x10x31
17	N030028	6	平垫-8x24x2-不锈钢	WASHER 8x24x2 A2
18	N010144	2	外六角-M8x50-不锈钢	SCREW M8x50 A2
19	N100005	4	四星螺帽 M8x22	NUT M8x22
20	C020253	2	万向轮星型把手 M10	UNIVERSAL WHEEL STAR HANDLE M10

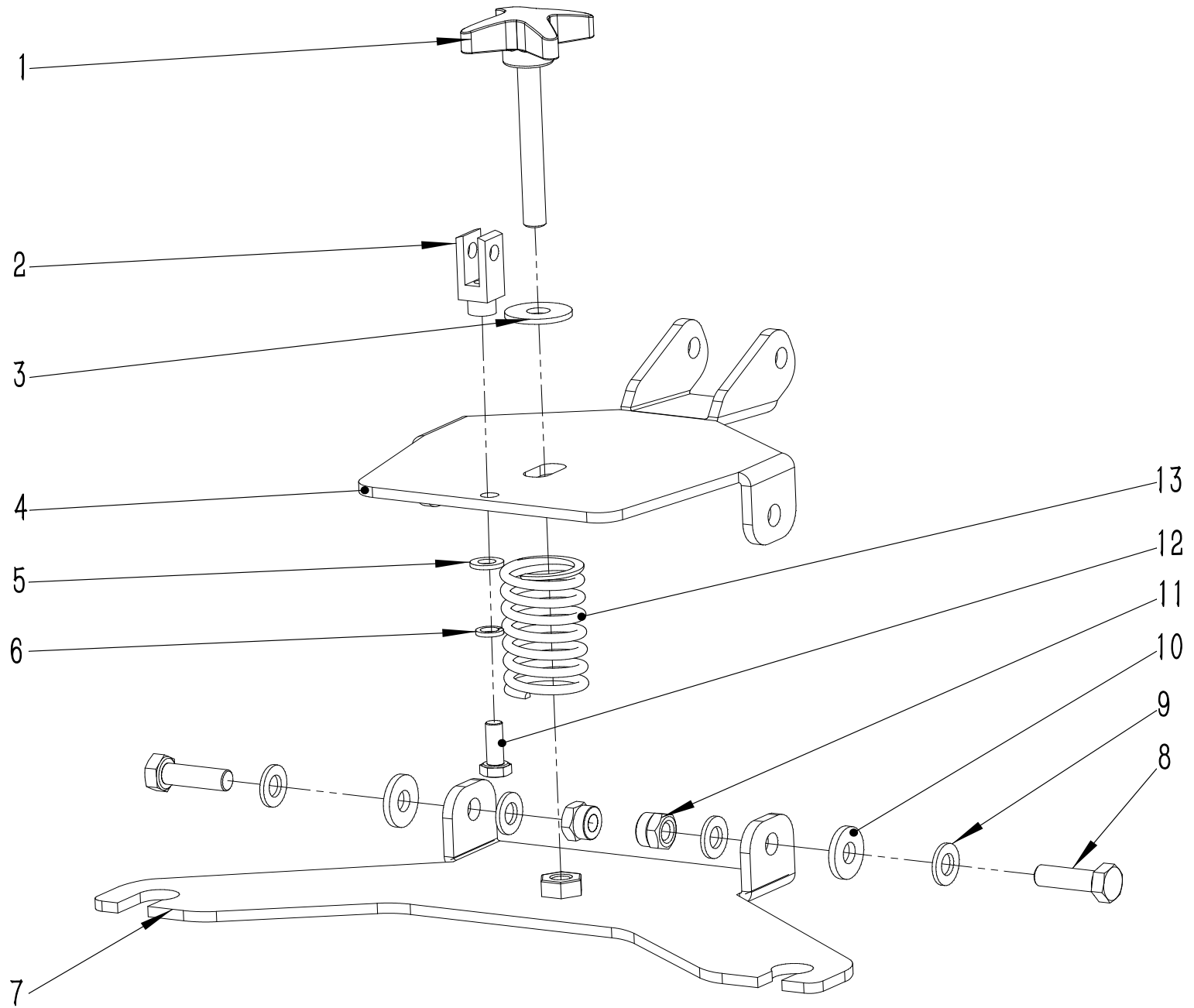

项目号 ITEM	零件号 P/N	数量 QTY	名称	DESCRIPTION
1	N100036	1	调节手柄-M8x50-黄色	ADJUSTER Y M8x50
2	N060006	1	夹片式-Y型接头-Y-16	Y-CONNECTOR Y-16
3	N030028	1	平垫-8x24x2-不锈钢	WASHER 8x24x2 A2
4	A050063	1	扒头上支架 T35	SUPPORT UP T35
5	N030007	1	平垫-6x12x1.6-镀锌	WASHER 6x12x1.6 ZINC
6	N040001	1	弹垫-M6-镀锌	LOCK WASHER M6 ZINC
7	A050064	1	扒头下支架 T35	SUPPORT DOWN T35
8	N010094	2	外六角-M8x25-不锈钢	SCREW M8x25 A2
9	N030010	4	平垫-8x16x1.6-不锈钢	WASHER 8x16x1.6 A2
10	B050058	2	四氟垫片 D8.2xD20x2.5	WASHER Φ 8.2x Φ 20x2.5
11	N020024	2	自锁螺母-M8-不锈钢	LOCK NUT M8 A2
12	N010005	1	外六角-M6x16-镀锌	SCREW M6x16 ZINC
13	B070027	1	压簧 D3.5xD30x48 (7圈)	SPRING Φ 3.5x Φ 30x48

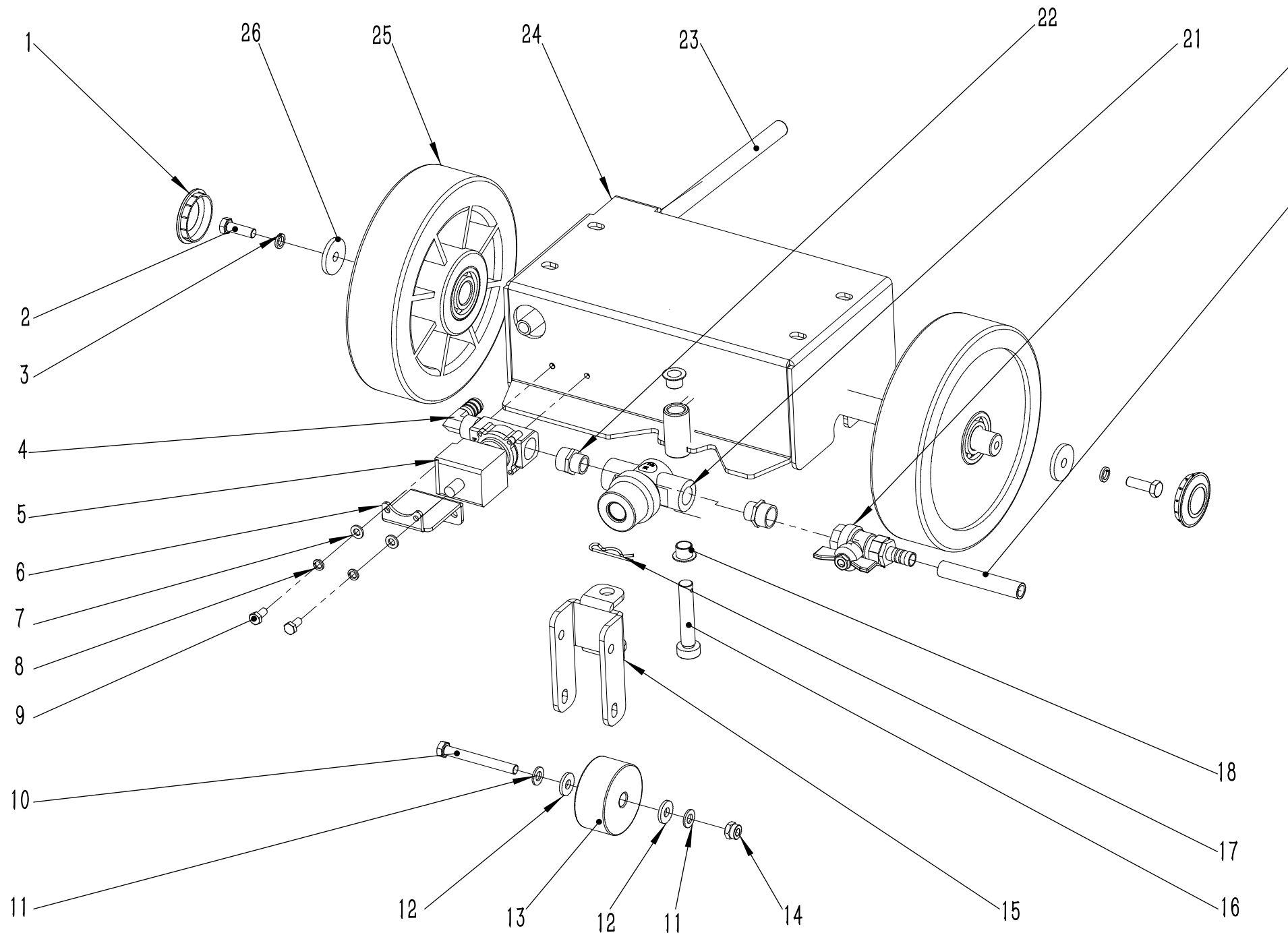

项目号 ITEM	零件号 P/N	数量 QTY	名称	DESCRIPTION
1	C020036	2	脚轮盖 D50	COVER D50
2	N010007	2	外六角-M8x25-镀锌	SCREW M8x25 ZINC
3	N040013	2	弹垫-M8-镀锌	LOCK WASHER M8 ZINC
4	F020004	1	快速弯头 1/2	CONNECTOR BEND 1/2
5	W020242	1	电磁阀组件-24V-10W	SOLENOID VALVE ASSEMBLY 24V 10W
6	A030076	1	水阀支架 58×50	SUPPORT 58×50
7	N030024	2	平垫-6x12x1.6-不锈钢	WASHER 6x12x1.6 A2
8	N040011	2	弹垫-M6-不锈钢	LOCK WASHER M6 A2
9	N010145	2	外六角-M6x12-不锈钢	SCREW M6x12 A2
10	N010127	1	外六角-M8x70-不锈钢-全牙	SCREW M8x70 A2
11	N030010	2	平垫-8x16x1.6-不锈钢	WASHER 8x16x1.6 A2
12	B050058	2	四氟垫片 D8. 2xD20x2. 5	WASHER Φ8. 2xΦ20x2. 5
13	N110034	1	定向轮 2.5 寸	WHEEL 2.5 INCH
14	N020024	1	自锁螺母-M8-不锈钢	LOCK NUT M8 A2
15	A050062	1	扒头支架转换座 T35	SUPPORT COUPLING T35
16	B060124	1	连接销 D12x70	CONNECTING PIN Φ12x70
17	N100035	1	R 型弹簧插销 D2x40	BOLT TYPE R
18	B050059	2	尼龙轴套 D12xD14x11	SPACER NYLON Φ12xΦ14x11
19	F050065. 5	1	硅胶水管 D=14 d=10 L=80	SILICONE HOSE D=14 d=10 L=80
20	F010006	1	蝶形球阀-1/2-直接头 D=10	BALL VALVE 1/2 CONNECTION STRAIGHT D=10
21	F010004	1	过滤器 78x36x60	FILTER 78x36x60
22	F020019	2	外丝接头-1/2-3/8-不锈钢	CONNECTOR 1/2-3/8 A2

23	F050065.4	1	硅胶水管 D=14 d=10 l=415	SILICONE HOSE D=14 d=10 L=415
24	A030075	1	底座架 T35	FRAME T35
25	C020012	2	轴承从动轮 D200x50	DRIVEN WHEEL Φ 200x50
26	B060069	2	平垫-8.5x30x4-镀锌	WASHER 8.5x30x4 ZINC

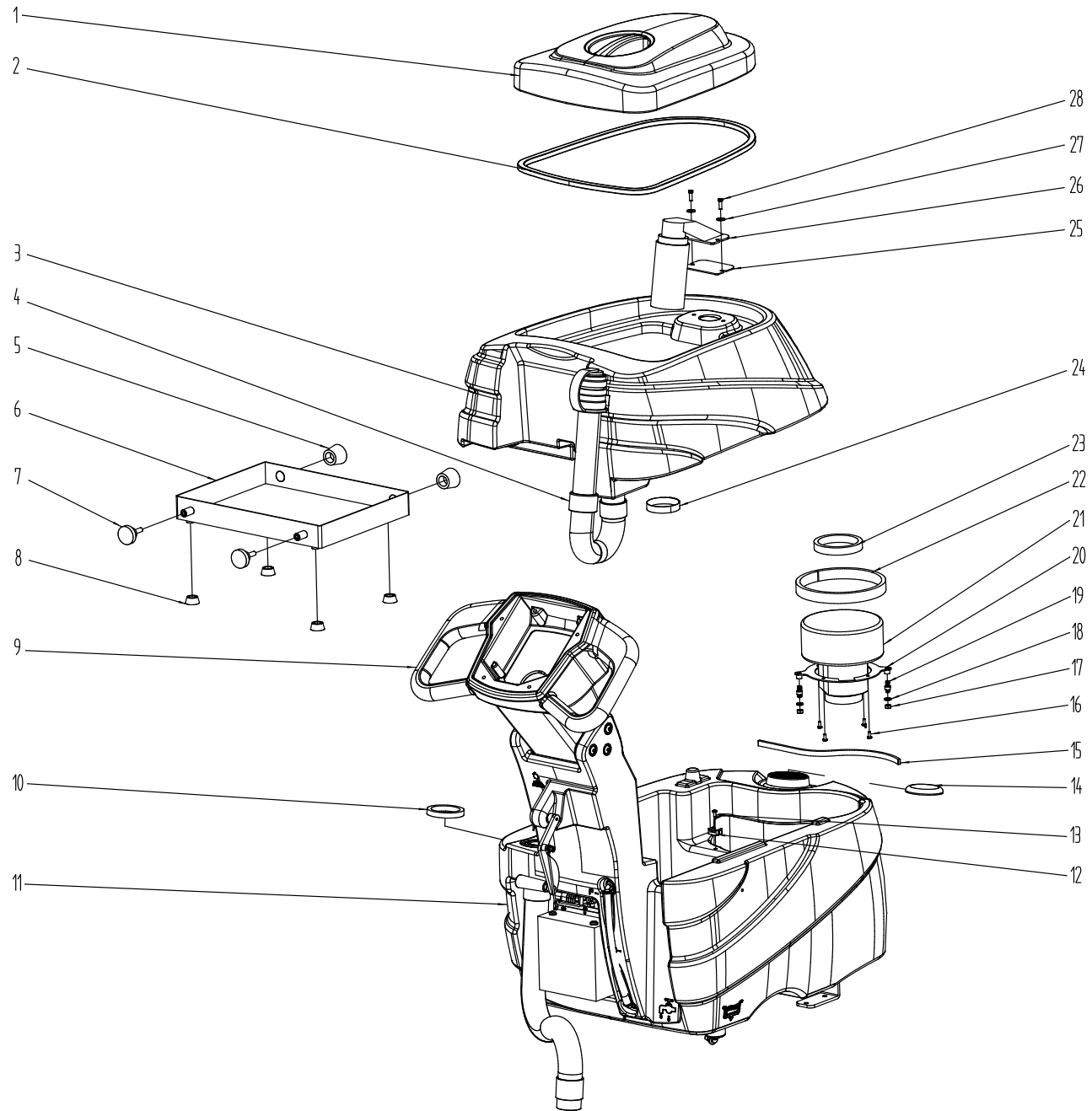

项目号 ITEM	零件号 P/N	数量 QTY	名称	DESCRIPTION
1	C010059	1	污水箱盖板-T35-黑色	RECOVERY TANK COVER T35 BLACK
2	N090010.4	1	密封胶条 19.5x9.5x9 L=1300	RUBBER 19.5x9.5x9 L=1300
3	C010058	1	污水箱-T35-绿色	RECOVERY TANK T35 GREEN
4	F060019	1	排污管 D38x650	DRAINAGE PIPE Φ38x650
5	C020059	2	橡胶减震垫 38x30x27	RUBBER DAMPING PAD 38x30x24
6	A030077	1	电池盒 345x268x45	BATTERY BASE 345x268x45
7	C020060	2	调节减震垫 M8	ADJUSTING RUBBER PAD M8
8	C020058	4	橡胶减震垫 26x20x12	RUBBER DAMPING PAD 26x20x12
9	C010060	1	手柄盒-T35-黑色	HANDLE BAR BLACK
10	N090051	1	吸污口密封条 D54	SUCTION SEAL STRIP Φ54
11	C010057	1	清水箱-T35-绿色	SOLUTION TANK T35 GREEN
12	N090002	5	扎带固定座 23x17	SUPPORT 23x2
13	N010225	13	盘头十字-M4x10-不锈钢	SELF TAPPING SCREW M4x10 A2
14	C020048	1	清水箱注水口盖子 D76	THREADED COVER Φ76
15	N090010.5	1	密封胶条 19.5x9.5x9 L=315	RUBBER 19.5x9.5x9 L=315
16	N010052	4	圆头十字自攻螺丝-M4.2x16-不 锈钢	SELF TAPPING SCREW M4.2x16 A2
17	N020022	2	螺母-M6-镀锌	NUT M6 ZINC
18	N030007	3	平垫-6x12x1.6-镀锌	WASHER 6x12x1.6 ZINC
19	N090048	2	橡胶减震垫 M6	RUBBER SHOCK PAD M6
20	A040061	1	真空电机安装板 T35	SUCTION SUPPORT T35
21	W020555	1	真空电机组件-24V-500W-直通式	VACUUM MOTOR ASSEMBLY -24V-500W

22	F040009	1	单面泡沫胶-20MM-L=920	FOAM GLUE 15mm
23	N090053	1	进风口密封条 D75	AIR INTAKE SEAL STRIP Φ75
24	F050006	1	卡箍 D33-57	SCREW CLAMP Φ33-57
25	C030040	1	吸水口密封垫 T35	SUCTION GASKET T35
26	F040010	1	吸水口浮球 T35	SEWAGE TANK FLOAT FILTER
27	N030022	2	平垫-6x18x1.6-不锈钢	WASHER 6*18*1.6 A2
28	N010226	2	外六角-M6x16-黑色 PP	SCREW M6x16 BLACK PP

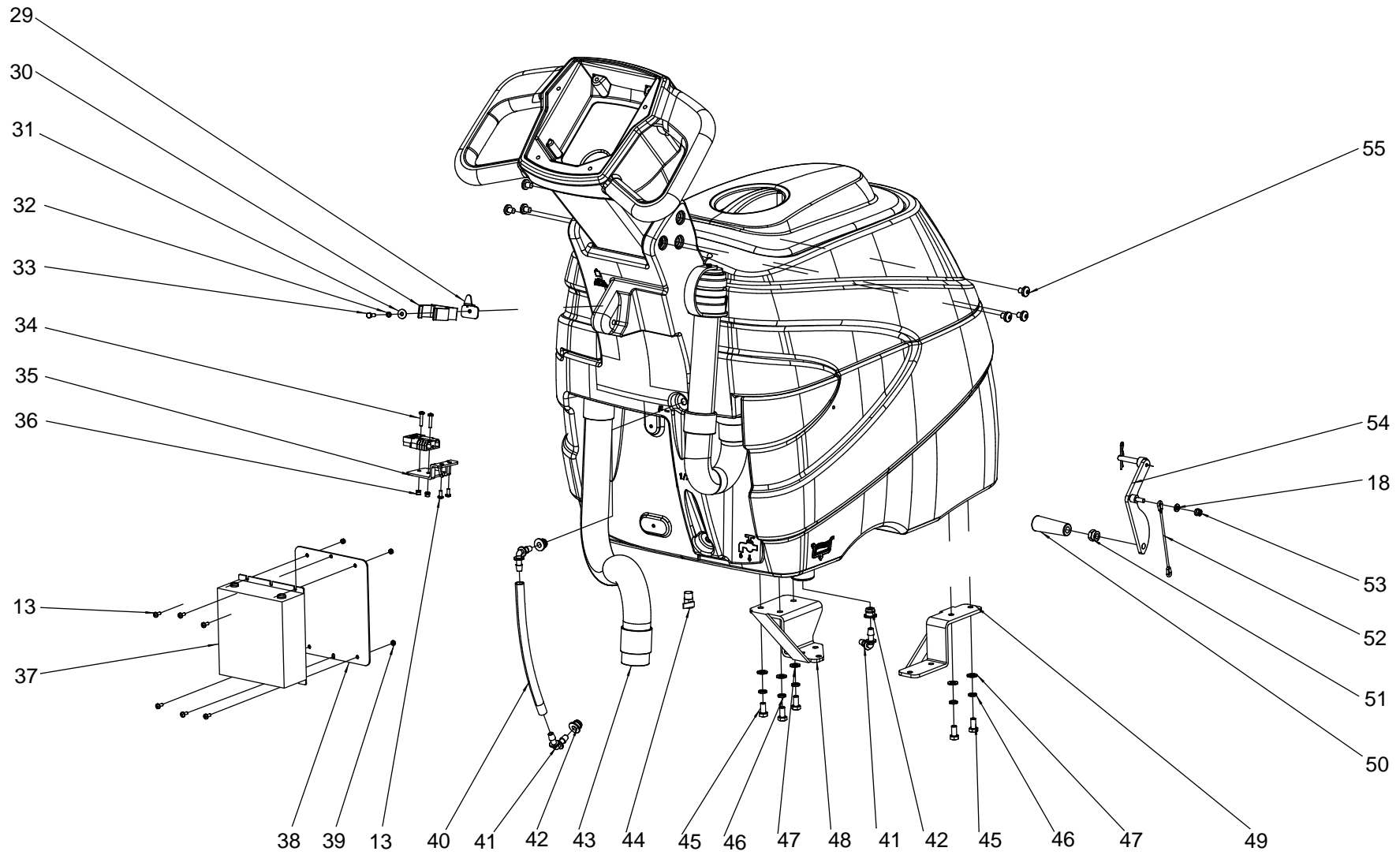

项目号 ITEM	零件号 P/N	数量 QTY	名称	DESCRIPTION
29	A060024	1	排污管挂钩 T35	DRAINAGE PIPE POTHOOK T35
30	C020014	1	管托 D43	SCREW CLAMP Φ 43
31	N030040	1	平垫-5x15x1-不锈钢	WASHER 5*15*1.5 A2
32	N040023	1	弹垫-M5-不锈钢	LOCK WASHER M5
33	N010029	1	外六角-M5X16-不锈钢	SCREW M5x16 A2
34	N010096	2	圆头十字-M4x20-不锈钢	SCREW M4x20 A2
35	A060026	1	充电器接口安装板 T35B	BRACKET OF CHARGER INTERFACE T35B
36	N020042	2	自锁螺母-M4-不锈钢	LOCK NUT M4 A2
37	E040083	1	充电器组件-24V-10A-超威	CHARGER 24V 10A CW
38	A060025	1	充电器安装板 T35B	BATTERY CHARGER SUPPORT T35B
39	N020042	2	自锁螺母-M4-不锈钢	LOCK NUT M4 A2
40	F050042.4	1	PU 水管-D=12 d=8 L=240	PU WATER PIPE D=12 d=8 L=240
41	F020001	3	快速接头 D(8-6)x30	CONNECTOR Φ (8-6)x30
42	C030013	3	密封垫 D8	GASKET Φ 8
43	F060020	1	吸污管-D.38x650-PU+PVC	SUCTION HOSE D.38x650 PU+PVC
44	F010009	1	排水阀-1/2	DRAIN VALVE 1/2
45	N010143	5	外六角-M8x16-不锈钢	SCREW M8x16 A2
46	N040017	5	弹垫-M8-不锈钢	LOCK WASHER M8
47	N030010	5	平垫-8x16x1.6-不锈钢	WASHER 8x16x1.6 A2
48	A040063	1	机头左安装支座 140x100x67	MOUNTING BRACKET LEFT 140x100x67
49	A040062	1	机头右安装支座 180x45x70	MOUNTING BRACKET RIGHT 180x45x70
50	N100004	1	提升摇臂把手 M10	HANDLE M10

项目号 ITEM	零件号 P/N	数量 QTY	名称	DESCRIPTION
51	N020002	1	自锁螺母-M10-镀锌	LOCK NUT M10 ZINC
52	B060125	1	扒头拉线 L=490MM	CABLE L=490MM
53	N020012	1	自锁螺母-M6-镀锌	LOCK NUT M6 ZINC
54	A050065	1	扒头提升摇臂 T35	LEVER T35
55	N010181	6	圆头内六角带平垫-M8x30-不锈钢	SCREW M8x30

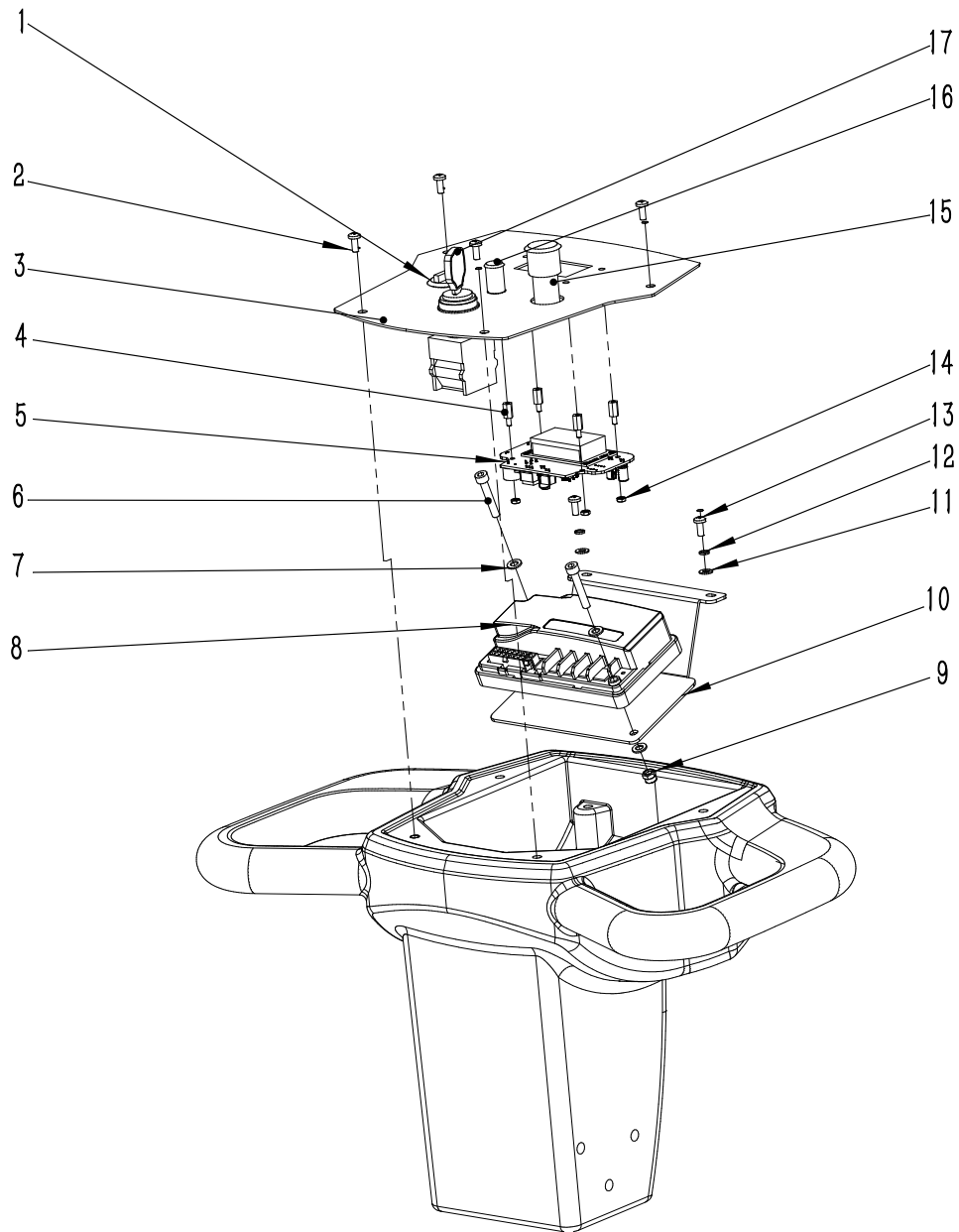

项目号 ITEM	零件号 P/N	数量 QTY	名称	DESCRIPTION
1	E020072	1	三档旋钮开关-24V-绿-D22-T35B	THREE SPEED KNOB SWITCH-24V-GREEN-D22-T35B
2	N010103	4	沉头十字-M3x8-不锈钢	SCREW M3x8 A2
3	A020060	1	控制面板 T35B-D-con	CONTROL PANEL D-con T35B
4	B020043	4	尼龙螺柱 M3x10+6	NYLON STUD M3x10+6
5	W020581	1	控制面板组件-T35B-D-con	CONTROL PANEL D-con T35B
6	N010246	2	内六角圆柱螺丝-HM5x30-不锈钢	SCREW HM5x30 A2
7	N030016	4	平垫-5x10x1-不锈钢	WASHER 5x10x1
8	W020395	1	大能控制器 T35B	DALA CONTROLLER T35B
9	N020037	2	自锁螺母-M5-不锈钢	LOCK NUT M5 A2
10	A020061	1	控制器安装板大能 T35B	CONTROLLER MOUNTING PLATE DALA T35B
11	N030053	2	平垫-4x9x1-不锈钢	WAHSE 4x9x1 ZINC
12	N040019	2	弹垫-M4-不锈钢	LOCK WASHER M4
13	N010225	6	盘头十字-M4x10-不锈钢	SELF TAPPING SCREW M4x10 A2
14	B060165	4	尼龙螺母 M3	NYLON NUT M3
15	E030028	1	按钮开关自锁带灯-24V-D22	SWITCH SELF-LOCKING 24V Φ22
16	W020243	1	自复位按键开关组件-M12-不锈钢	SELF RESET KEY SWITCH ASSEMBLY M12 A2
17	W020013	1	钥匙开关组件 双开	KEY SWITCH ASSEMBLY
18	C040180	1	控制面板标签-T35B-绿色-控水开关	CONTROL PANEL LABEL GREEN T35B WATER CONTROL SWITCH

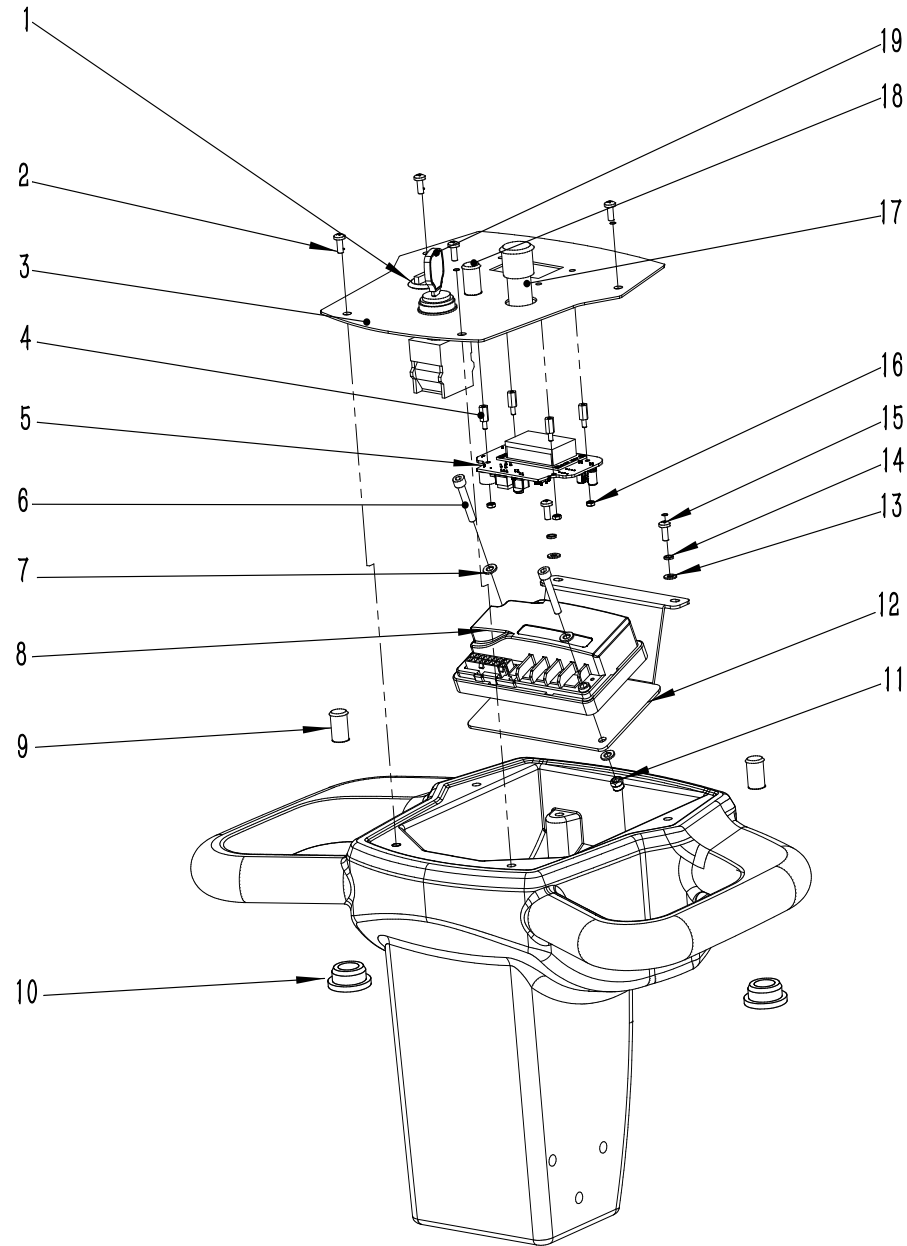

项目号 ITEM	零件号 P/N	数量 QTY	名称	DESCRIPTION
1	E020072	1	三档旋钮开关-24V-绿-D22-T35B	THREE SPEED KNOB SWITCH-24V-GREEN-D22-T35B
2	N010103	4	沉头十字-M3x8-不锈钢	SCREW M3x8 A2
3	A020060	1	控制面板 T35B-D-con	CONTROL PANEL D-con T35B
4	B020043	4	尼龙螺柱 M3x10+6	NYLON STUD M3x10+6
5	W020581	1	控制面板组件-T35B-D-con	CONTROL PANEL D-con T35B
6	N010246	2	内六角圆柱螺丝-HM5x30-不锈钢	SCREW HM5x30 A2
7	N030016	4	平垫-5x10x1-不锈钢	WASHER 5x10x1
8	W020395	1	大能控制器 T35B	DALA CONTROLLER T35B
9	W020557	2	自复位按键开关组件 2-M12	SELF RESET KEY SWITCH ASSEMBLY2-M12
10	C090015	2	橡胶盖	ROBBER COVER
11	N020037	2	自锁螺母-M5-不锈钢	LOCK NUT M5 A2
12	A020061	1	控制器安装板大能 T35B	CONTROLLER MOUNTING PLATE DALA T35B
13	N030053	2	平垫-4x9x1-不锈钢	WAHSE 4x9x1 ZINC
14	N040019	2	弹垫-M4-不锈钢	LOCK WASHER M4
15	N010225	6	盘头十字-M4x10-不锈钢	SELF TAPPING SCREW M4x10 A2
16	B060165	4	尼龙螺母 M3	NYLON NUT M3
17	E030028	1	按钮开关自锁带灯-24V-D22	SWITCH SELF-LOCKING 24V Φ22
18	W020243	1	自复位按键开关组件-M12-不锈钢	SELF RESET KEY SWITCH ASSEMBLY M12 A2
19	W020013	1	钥匙开关组件 双开	KEY SWITCH ASSEMBLY
20	C040180	1	控制面板标签-T35B-绿色-控水开关	CONTROL PANEL LABEL GREEN T35B WATER CONTROL SWITCH

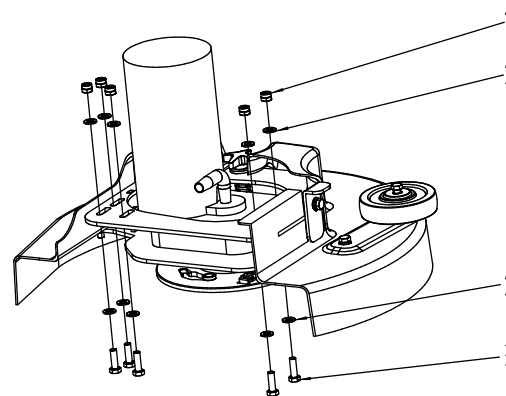
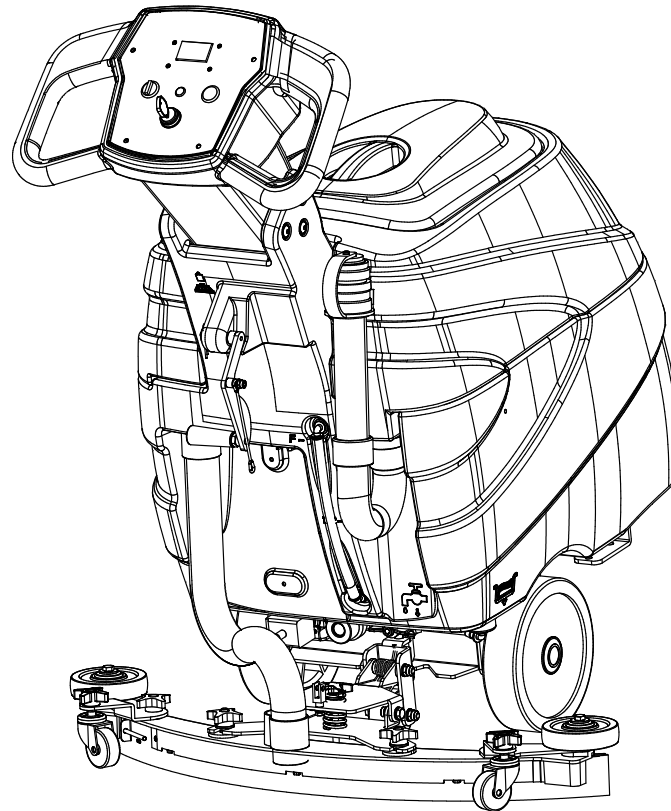

项目号 ITEM	零件号 P/N	数量 QTY	名称	DESCRIPTION
1	N020024	5	自锁螺母-M8-不锈钢	LOCK NUT M8 A2
2	N030010	10	平垫-8x16x1.6-不锈钢	WASHER 8x16x1.6 A2
3	N010094	5	外六角-M8x25-不锈钢	SCREW M8x25 A2

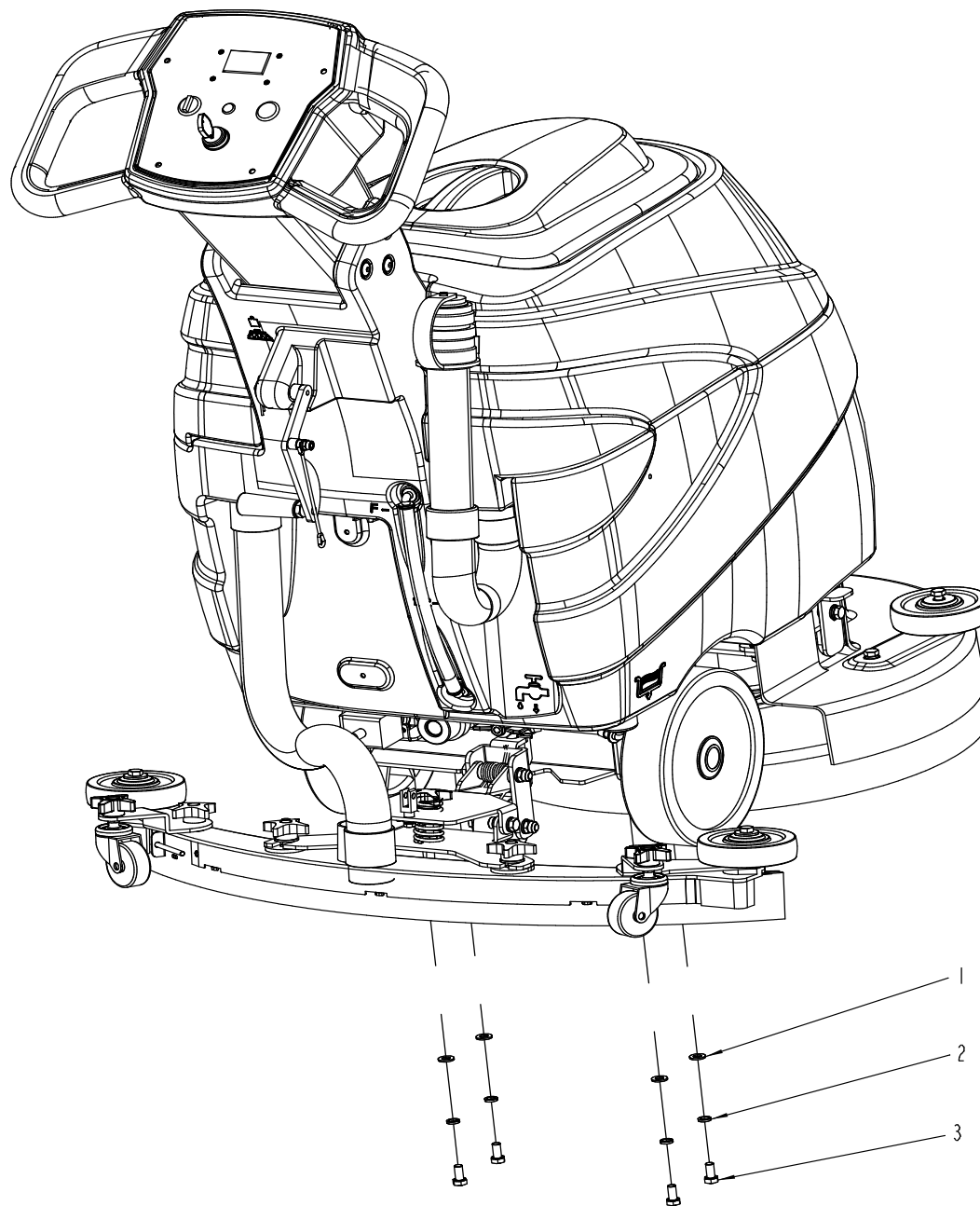

项目号 ITEM	零件号 P/N	数量 QTY	名称	DESCRIPTION
1	N030010	4	平垫-8x16x1.6-不锈钢	WASHER 8x16x1.6 A2
2	N040017	4	弹垫-M8-不锈钢	LOCK WASHER M8
3	N010143	4	外六角-M8x16-不锈钢	SCREW M8x16 A2

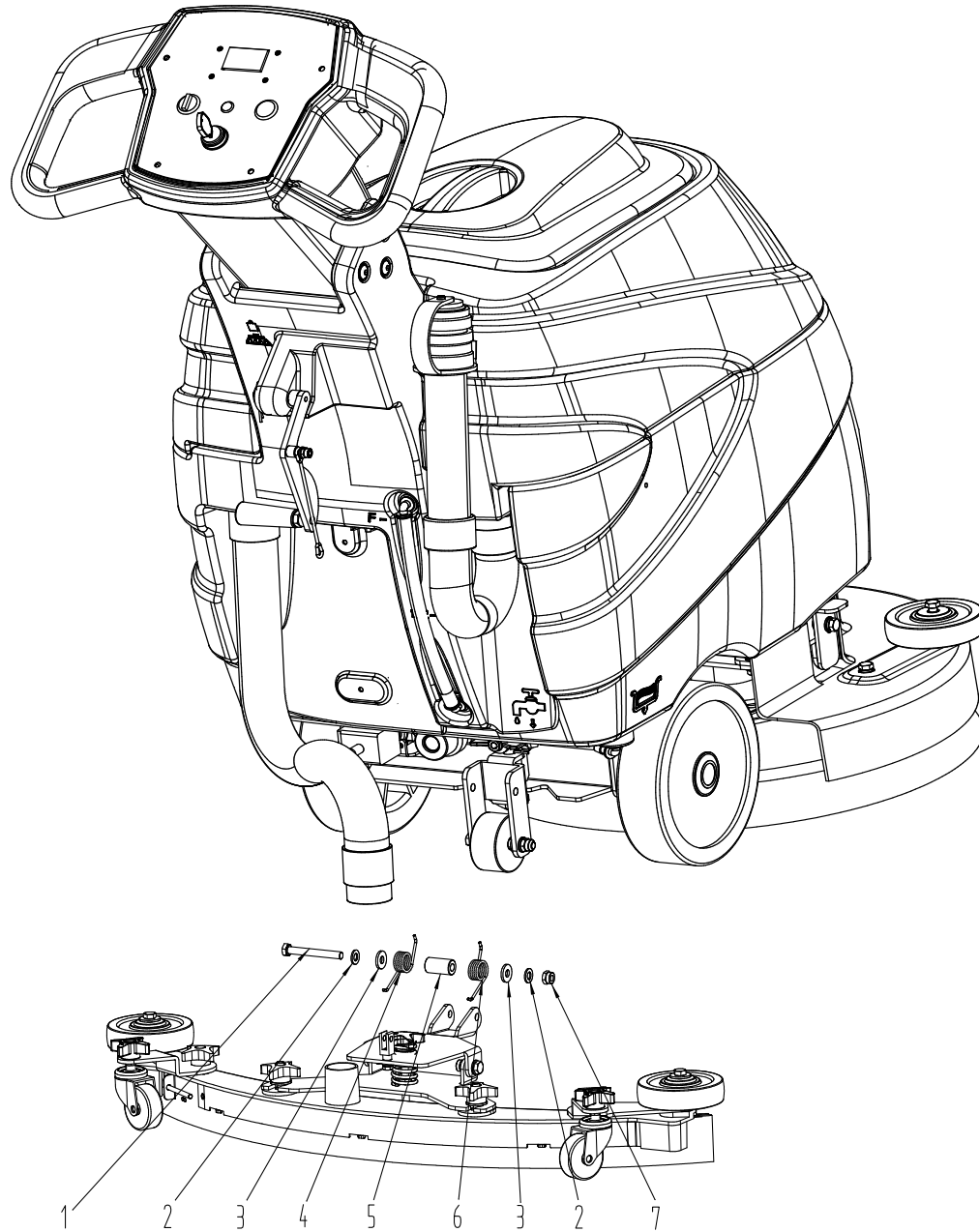

项目号 ITEM	零件号 P/N	数量 QTY	名称	DESCRIPTION
1	N010127	1	外六角-M8x70-不锈钢-全牙	SCREW M8x70 A2
2	N030010	2	平垫-8x16x1.6-不锈钢	WASHER 8x16x1.6 A2
3	B050058	2	四氟垫片 D8.2xD20x2.5	WASHER $\Phi 8.2 \times \Phi 20 \times 2.5$
4	B070048	1	异型压簧 D20xD2.5X15.6-L	SPRING D20xD2.5X15.6-L
5	B010064	1	轴套 D16xD9X32	BUSH D16xD9X32
6	B070049	1	异型压簧 D20xD2.5X15.6	SPRING D20xD2.5X15.6
7	N020024	1	自锁螺母-M8-不锈钢	LOCK NUT M8 A2

项目号 ITEM	零件号 P/N	数量 QTY	名称	DESCRIPTION
1	M010015	1	塑料包装袋 1400x700x1000	PLASTIC PACKAGE BAG 1400x700x1000
2	M020026	1	木托盘-1120x590x120-T35	WOOD PALLET 1120x590x120 T35
3	M020008	4	三角挡块 50x50x100	TRIANGLE BLOCK 50x50x100
4	HC10015	2	尼龙编织带长 545x35mm	NYLON BRAIDED TAPE LONG 545x35
5	M010037	1	纸箱上盖-1170x640x100-T35	CARTON BOX COVER T35 1170x640x100
6	M010009	1	纸盒-820x200x120-扒头 760	760 SQUEEGEE CARTON BOX 820x200x120
7	M010014	1	说明书自封袋 340x240mm	PLASTIC PACKAGE BAG 340x240mm
8	M020007	12	支撑护角 50x50x100	ANGLE BEAD 50x50x100
9	M020005	4	木条-40x40x980-45L	BATTEN 45L 40x40x980
10	M020024	2	三角挡块 50x50x70	TRIANGLE BLOCK 50x50x70
11	HC10005	20	P 钉	P NAIL
12	HC10017	12	封箱钉 35mmx18mm	SEALING BOX NAIL 35mmx18mm
13	M010046	1	刷盘防护膜	BRUSH GUARD FOAM
14	N010160	8	沉头十字自攻螺丝-ST4x40-镀黑锌	SELF TAPPING SCREW ST4x40 BLACK ZINC
15	N010159	4	沉头十字自攻螺丝-ST4x25-镀黑锌	SELF TAPPING SCREW ST4x25 BLACK ZINC
16	N100042	1	内六角扳手 规格 5	HEXAGONAL WRENCH Φ5

项目号 ITEM	零件号 P/N	数量 QTY	名称	DESCRIPTION
1	C040180	1	控制面板标签-T35B-绿色-控水开关	CONTROL PANEL LABEL GREEN T35B WATER CONTROL SWITCH
2	C040127	1	左侧标签 T35	LEFT LABEL T35
3	C040128	1	右侧标签 T35	RIGHT LABEL T35
4	C040129	1	标识标签 T35	DECAL T35
5	M010036	1	纸箱-1120x590x1000-T35	CARTON BOX T35 1120x590x1000
6	P010004	1	保修卡	WARRANTY CARD
7	P010012	1	测试报告	TEST REPORT
8	N090031	2	钥匙挂件	KEYCHAIN
9	C040198	1	手柄安装指导标贴 T35	HANDLE INSTALLATION GUIDANCE LABEL T35
10	M010042	1	前包装膜 T35	T35 FRONT PACKAGING FOAM
11	M010043	1	后包装膜 T35	T35 BEHIND PACKAGING FOAM
12	M010044	1	左包装膜 T35	T35 LEFT PACKAGING FOAM
13	M010045	1	右包装膜 T35	T35 RIGHT PACKAGING FOAM



项目号 ITEM	零件号 P/N	数量 QTY	名称	DESCRIPTION
1	C030138PU	1	前刮条-PU-3×50×785	FRONT STRIP-PU-3×50×785
2	C030139PU	1	后刮条-PU- 4×53×835	BACK STRIP-PU- 4×53×835
3	C030038LTX	1	前橡皮刮条-LTX-3x50x785	FRONT SQUEEGEE STRIP-LINATEX-3x50x785
4	C030039LTX	1	后橡皮刮条-LTX-4×53×835	BACK SQUEEGEE STRIP-LINATEX-4×53×835
5	C030138LAT	1		FRONT SQUEEGEE STRIP-LATEX3x50x785
6	C030139LAT	1		BACK SQUEEGEE STRIP-LATEX-4×53×835
7	N150001	1	刷盘 T-19 英寸-PP0.6	BRUSH 19" PP0.6
8	N150004	1	针盘 T 19 英寸	PAD HOLDER-19"
9	N150006	1	刷盘 T-19 英寸-PP0.28	BRUSH -19"-PP0.28
10	N150045	1	锁水刷盘 T 19 英寸	BRUSH WATER LOCK -19" PP0.5