

— SCHEMATIC DRAWINGS —

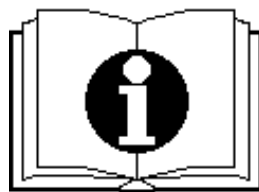

手推式洗地机

T55BT PRO

Scrubber Dryer

T55BT PRO

Issued in Aug . 2023

Version:V04

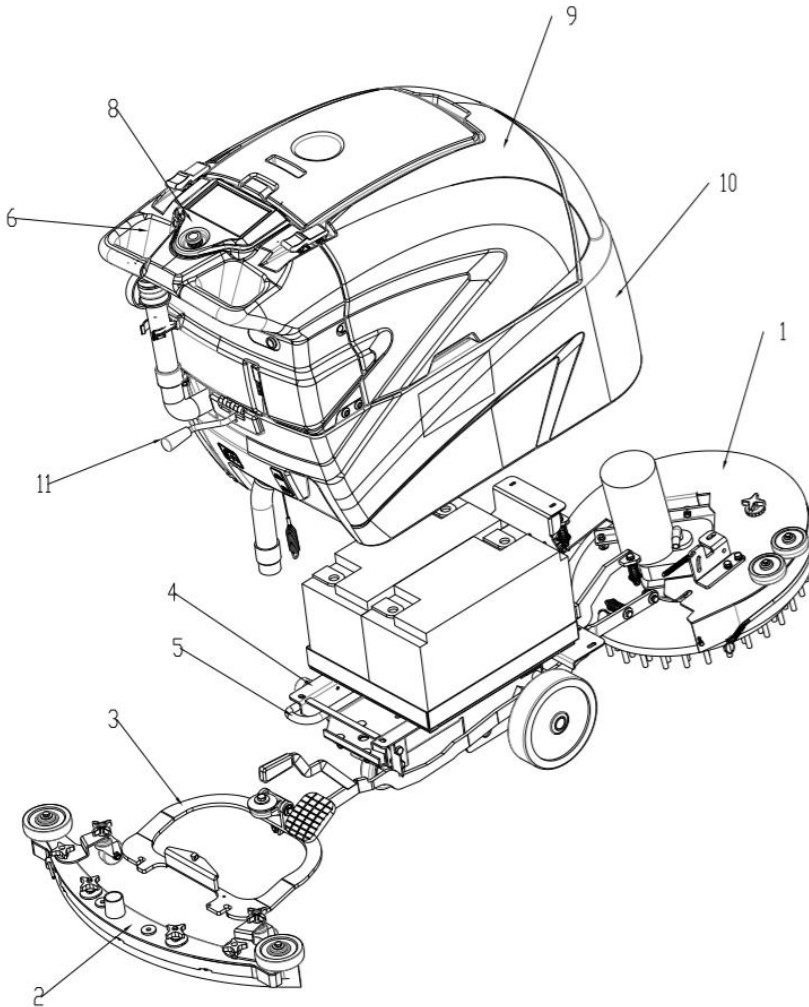

## MENU

1. 机头组件·····	1—4
NOSE ASSEMBLY	
2. 扒头组件·····	5—6
SQUEEGEE ASSEMBLY	
3. 扒头支架组件 ·····	7—8
SQUEEGEE CONTROL ASSEMBLY	
4. 底座架组件·····	9—14
FRAME ASSEMBLY	
5. 水路组件·····	15—16
WATER ASEEMBLY	
6. 手柄盒组件·····	17—18
HANDLE BOX ASSEMBLY	
7. 电路板支架组件·····	19—20
BOARD BRACKET ASSEMNLY	
8. 控制面板组件·····	21—22
CONTROL PANEL ASSEMBLY	
9. 污水箱组件·····	23—26
RECOVERY TANK ASESEMBLY	
10. 清水箱组件·····	27—28
WATER TANK ASESEMBLY	
11. 整机组件·····	29—30
MACHINE ASESEMBLY	
12. 包装组件·····	31—32
PACKAGING ASSEMBLY	
13. 附件·····	33—34
CUSTOM PACKAGE	

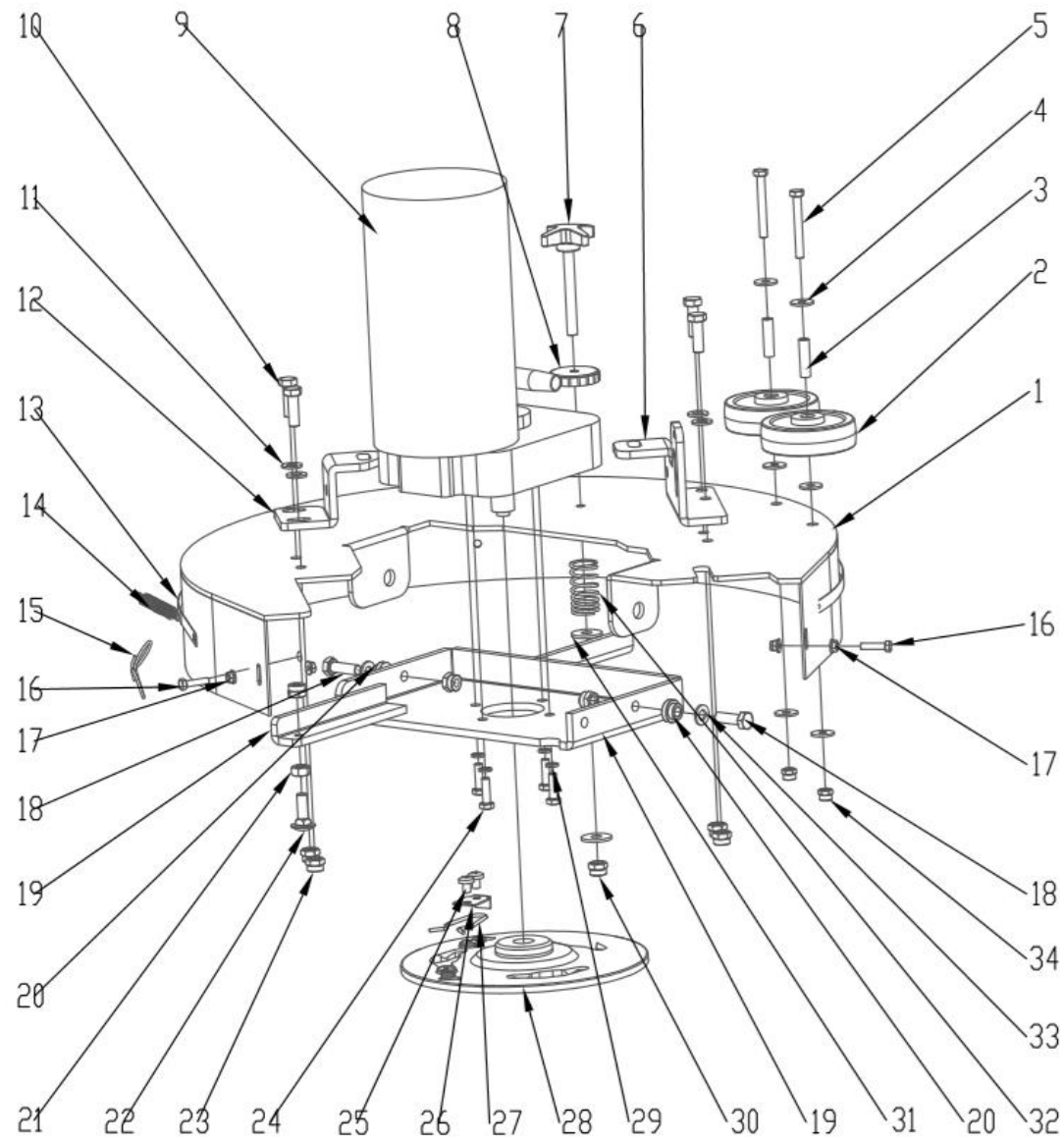

项目号 ITEM	零件号 P/N	名称	数量 QTY	DESCRIPTION
1	A040016A	机头外罩-5 度-20 英寸	1	COVER 5° 20"
1	A040055A	机头外罩-5 度-18 英寸	1	COVER 5° 18"
2	N110001	防撞轮 75X28	2	WHEEL Φ75
3	B020010	防撞轮铜套 6X8X30	2	BUSHING 6×8×30
4	N030022	大平垫 6×18×1.6 不锈钢	6	WASHER 6×18×1.6 A2
5	N010087	外六角 M6×50 不锈钢	2	SCREW M6×50 A2
6	A040114	机头支座-右	1	SUPPORT RIGHT
7	N100037	调节手柄 M8×70	1	ADJUSTER M8×70
8	N020009	花型螺母 M8	1	BUT M8
9	W020296	刷盘电机组件2	1	BRUSH MOTOR ASSEMBLY 24V 550W 220RPM
10	N010007	外六角 M8×25 镀锌	4	SCREW M8×25 ZINC
11	N030006	平垫 8×16×1.6 镀锌	4	WASHER 8×16×1.6 ZINC
12	A040113	机头支座-左	1	SUPPORT LEFT
13	A040019	防溅条紧固钢条 10X1050	1	BLADE 10×1050
14	B060012	钢条拉簧 1.1X10X55	1	SPRING 1.1×10×55
15	B070010	异型套圈 2X26	1	RING 2×26
16	N010135	外六角 M5×20 不锈钢	2	SCREW M5×20 A2
17	N020004	法兰面螺母 M5 镀锌	4	FLANGE NUT M5 ZINC
18	N010094	外六角 M8X25 不锈钢	2	SCREW M8×25 A2
19	A040012A	电机座 240X363	1	MOTOR SUPPORT 240×363
20	B020009	轴套 8X18X(8-3.5)	2	SPACER 8×18× (8-3.5)
21	N020051	螺母 M8 不锈钢	1	NUT M8 A2
22	N0100014	大圆头方颈螺栓 M8×25 镀锌	1	SCREW M8×25 ZINC
23	N020001	自锁螺母 M8 镀锌	4	LOCK NUT M8 ZINC
24	N010006	外六角 M6×20 镀锌	4	SCREW M6×20 ZINC
25	N010179	盘头十字螺钉 M5X8 不锈钢	2	SCREW M5×8 A2
26	A040060	弹簧锁紧板	1	SPRING LOCK PLATE

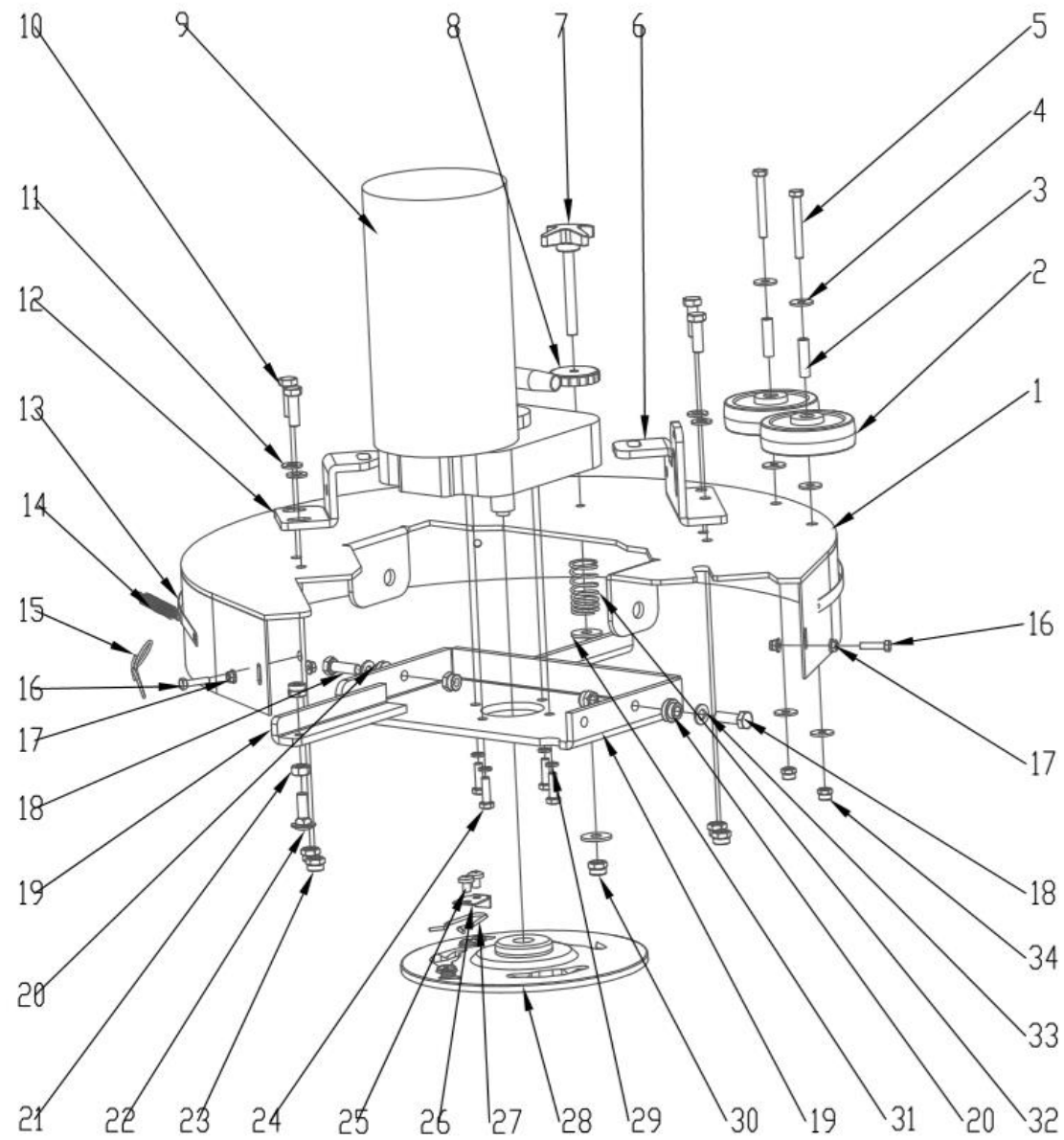

项目号 ITEM	零件号 P/N	名称	数量 QTY	DESCRIPTION
27	B060122	刷盘锁紧器弹簧	1	LOCK SPRING D2
28	D010030	刷盘锁紧器左	1	BRUSH HOLDER ASSFMBLY
29	N040001	弹垫 6 镀锌	4	LOCK WASHER M6 ZINC
30	N020024	自锁螺母 M8 不锈钢	4	LOCK M8 A2
31	N030028	大平垫 8×24×2 不锈钢	2	WASHER 8×24×2 A2
32	B070026	压缩弹簧 $\Phi 20 \times 38$ 线径 2.8	1	SPRING $\Phi 20 \times 38 \times 2.8$
33	N030010	平垫 8×16×1.6 不锈钢	2	WASHER 8×16×1.6 A2
34	N020006	自锁螺母 M6 不锈钢	2	LOCK NUT M6 A2

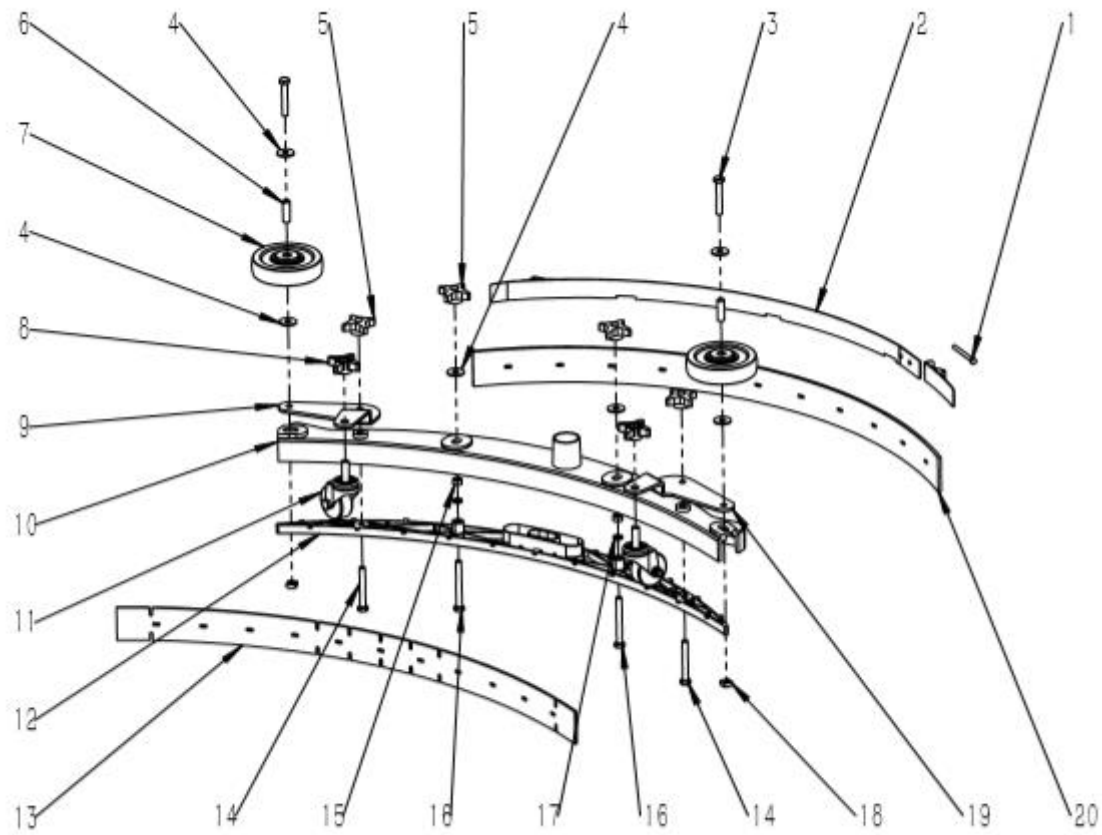



项目号 ITEM	零件号 P/N	名称	数量 QTY	DESCRIPTION
1	N010146	外六角-M5×55-不锈钢	1	SCREW M5×55 A2
2	A030035	扒头后固定钢板 820	1	PLATES 820
3	N010144	外六角-M8×50-不锈钢	2	SCREW M8×50 A2
4	N030028	平垫-8×24×2-不锈钢	6	WASHER 8×24×2 A2
5	N010047	四星螺帽 M8×22 黄色	4	NUT M8×22 YELLOW
6	B020027	防撞轮铜套 8×10×31	2	BUSHING 8×10×31
7	N110019	防撞轮 D100×29.5	2	WHEEL Φ100×29.5
8	C020369	万向轮星型把手 M10 黄色	2	UNIVERSAL WHEEL SYER HANDLE M10 YELLOW
9	A030105	万向轮支架右 760 新	1	SUPPORT RIGHT 760 NEW
10	D010046	扒头主体 760 黑色	1	SQUEEGEE BODY 760 BLACK
11	N110048	M10 螺杆万向轮 Φ50	2	M10 SCREW UNIVERSAL WHEEL Φ50
12	B050069	半月板 760 新	1	PLATE 760 NEW
13	C030014LAT	前刮皮-橡皮-3×50×785	1	FRONT SQUEEGE BLADE RUBBER LATEX 3×50×785
14	N010128	外六角-M8×60-不锈钢	2	SCREW M8×60 A2
15	N020010	螺母-M8-不锈钢	2	NUT M8 A2
16	N010127	外六角-M8×70-不锈钢-全压	2	SCREW M8×70 A2
17	N040017	弹垫-M8-不锈钢	2	LOCK WASHER M8
18	N020011	方形螺母-M8-13×13×6.5-不锈钢	2	NUT M8 13×13×6.5 A2
19	A030104	万向轮支架左 760 新	1	SUPPORT LEFT 760 NEW
20	C030015LAT	后刮条-橡皮-4.5×53×835	1	REAR SQUEEGE BLADE RUBBER LATEX 4.5×53×835



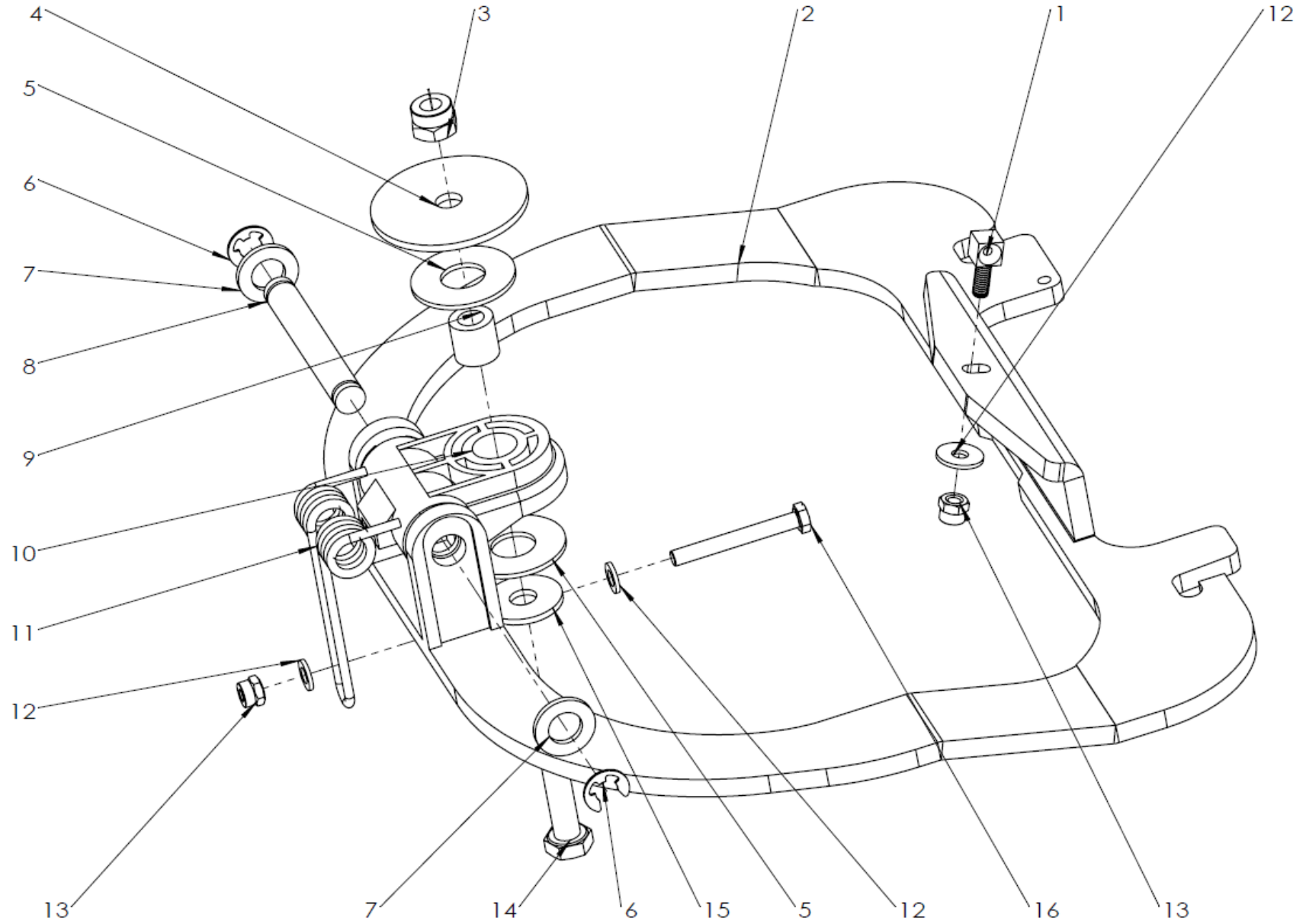

项目号 ITEM	零件号 P/N	名称	数量 QTY	DESCRIPTION
1	B060035	方头带孔螺栓-M6×25-镀锌	1	COUPLING M6×25 ZINC
2	N030008	平垫 6×18×1.6 镀锌	3	WASHER 6×18×1.6 ZINC
3	A050051	扒头支架 263	1	SUPPORT 263
4	B020003	铜套 10.2×17×16.5	1	BUSHING 10.2×17×16.5
5	N010026	外六角 M10×40 镀锌	1	SCREW M10×40 ZINC
6	N030041	平垫-10×30×2.5-镀锌	2	WASHER 10×30×2.5 ZINC
7	B050022	四氟垫片 10.2×60×3	1	WASHER 10.2×60×3
8	B050005	四氟垫片 17.2×40×2	2	WASHER 17.2×40×2
9	N030011	平垫 12×24×2.5 镀锌	2	WASHER 12×24×2.5 ZINC
10	N080005	卡簧 Φ9	2	CIRCLIP Φ9
11	B060099	转动轴 Φ12×86	1	AXIS OF ROTATION Φ12×86
12	B070016	压力弹簧 3.5×20×40.5	1	PRESSURE SPRING 3.5×20×40.5
13	N020012	自锁螺母 M6 镀锌	2	LOCK NUT M6 ZINC
14	D010007	转换座 58	1	COUPLING 58
15	N020002	自锁螺母 M10 镀锌	1	LOCK NUT M10 ZINC
16	N010021	外六角-M6×50-镀锌-全牙	1	SCREW M6×50 ZINC

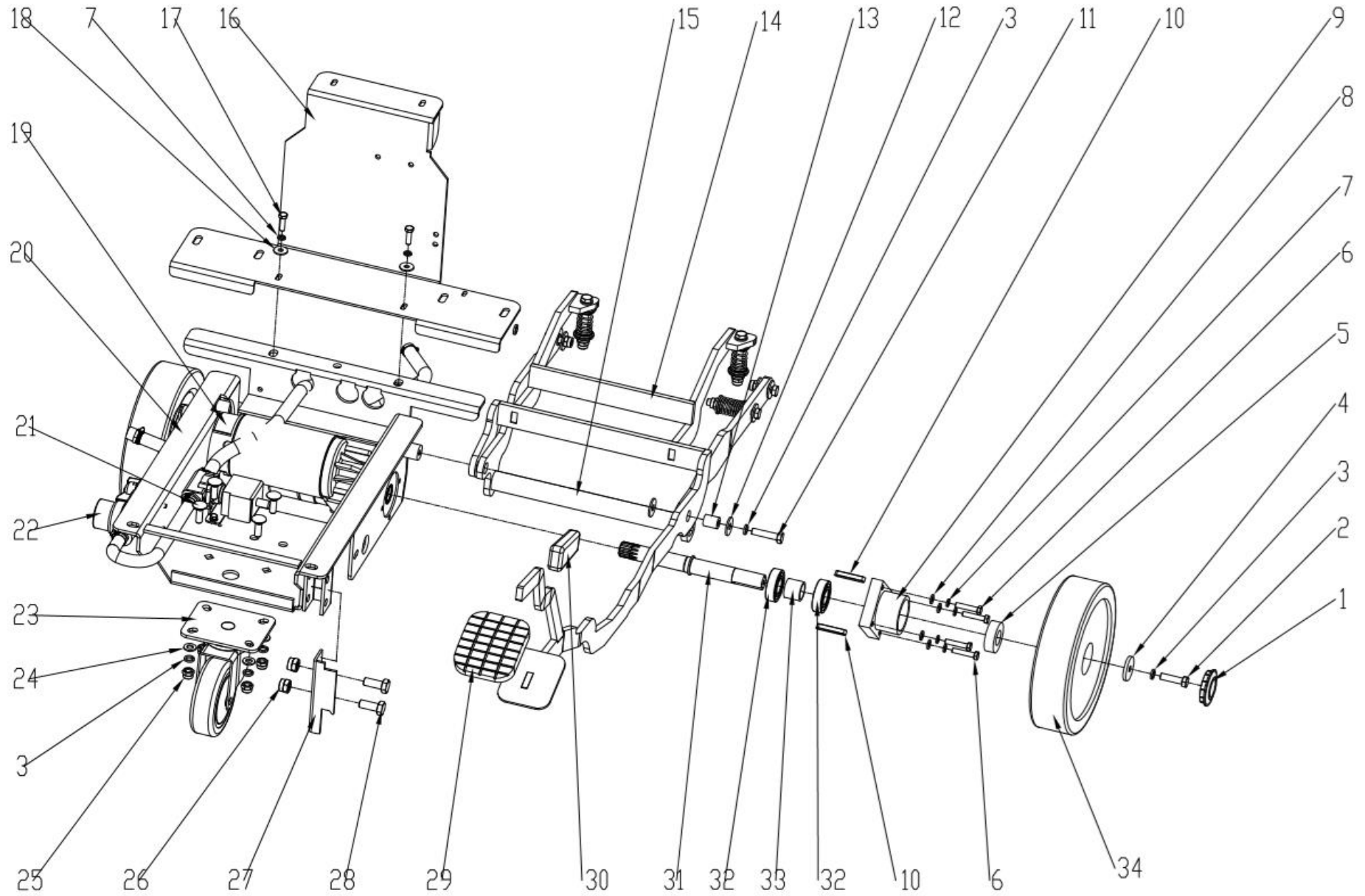

项目号 ITEM	零件号 P/N	名称	数量 QTY	DESCRIPTION
1	C020036	脚轮盖 $\Phi$ 50 黑色	2	COVER $\Phi$ 50 BLACK
2	N010002	外六角 M8x30 镀锌	4	SCREW M8x30 ZINC
3	N040013	弹垫 8 镀锌	10	LOCK WASHER M8 ZINC
4	B060069	平垫 8.2x32x4 镀锌	2	WASHER 8.2x32x4 ZINC
5	B050074	驱动轴挡圈	2	WASHER RING
6	N010033	外六角 M6x30 镀锌	8	SCREW M6x30 ZINC
7	N040001	弹垫 6 镀锌	10	LOCK WASHER M6 ZINC
8	N030007	平垫 6x12x1.6 镀锌	8	WASHER 6x12x1.6 ZINC
9	D010010	轴承座 $\Phi$ 70	2	BEARING SUPPORT $\Phi$ 70
10	N060001	平键 6X6X40	4	FLAT KEY 6x6x40
11	N010008	外六角 M8x35 镀锌	2	SCREW M8x35 ZINC
12	N030027	大平垫 8x24x2 镀锌	10	WASHER 8x24x2 ZINC
13	B020004	铜套 8.3x15x18.5	2	BUSHING 8.3x15x18.5
14	A020067	脚踏支架	1	PEDAL BRACKET
15	A040110	机头下支架 277	1	UNDER THE NOSE BRACKET 277
16	A040117	底座架前挡板	1	BASE FRAME FRONT BEZEL
17	N010006	外六角 M6x20 镀锌	2	SCREW M6x20 ZINC
18	N030008	大平垫 6x18x1.6 镀锌	4	WASHER 6x18x1.6 ZINC
19	W020297	驱动电机组件-24V-180W-3N.M	1	DRIVE MOTOR ASSEMBLY
20	A030115	55 加宽底座架	1	BASE FRAME T55
21	N010091	大圆头方径螺栓 M8x20 镀锌	4	SCREW M8x20 ZINC
22	W010018	水路组件 T55	1	WATER ASSEMBLY T55
23	N110004	万向轮 $\Phi$ 100	1	UNIVERSAL WHEEL $\Phi$ 100
24	N030006	平垫 8x16x1.6 镀锌	8	WASHER 8x16x1.6 ZINC
25	N020001	自锁螺母 M8 镀锌	9	LOCK NUT M8 ZINC
26	N020002	自锁螺母 M10 镀锌	2	LOCK NUT M10 ZINC

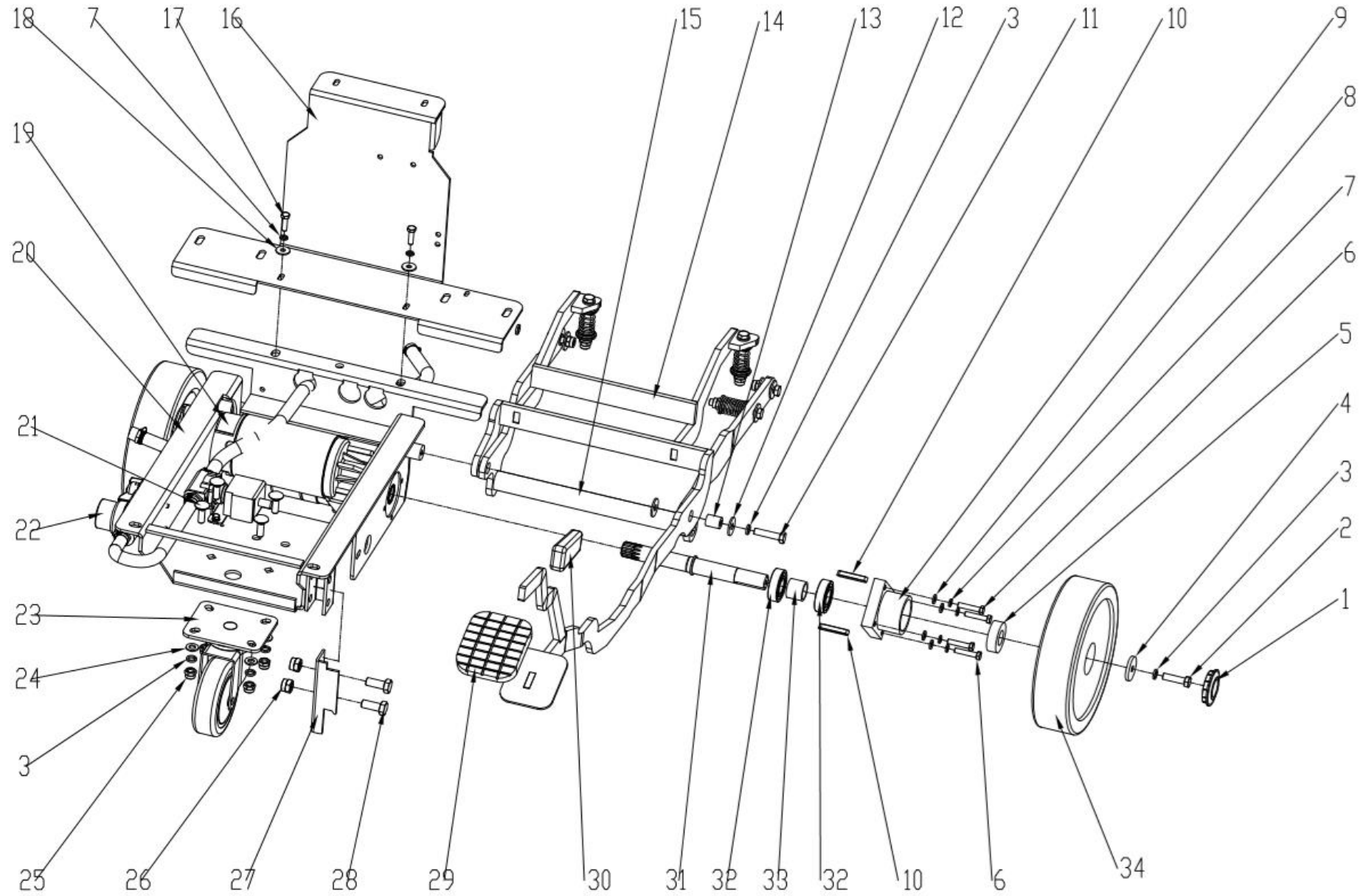

项目号 ITEM	零件号 P/N	名称	数量 QTY	DESCRIPTION
27	A040112	限位挡板	1	LIMIT STOP
28	N010060	外六角 M10x25 镀锌	2	SCREW M10x25 ZINC
29	C030006	脚踏垫 98x80	1	RUBBER PAD 98x80
30	N090094	提升手柄胶套 20x70	1	LIFTING HANDLE RUBBER SLEEVE 20x70
31	B010062	驱动轴 $\Phi 20 \times 194$	2	AXLE SHAFT $\Phi 20 \times 194$
32	N070001	轴承 6004	4	BEARING 6004
33	B060027	轴承垫圈 20x25x21	2	WASHER RING 20x25x21
34	C020004	$\Phi 200 \times 50$ 键槽脚轮	2	DRIVER WHEEL $\Phi 200 \times 50$



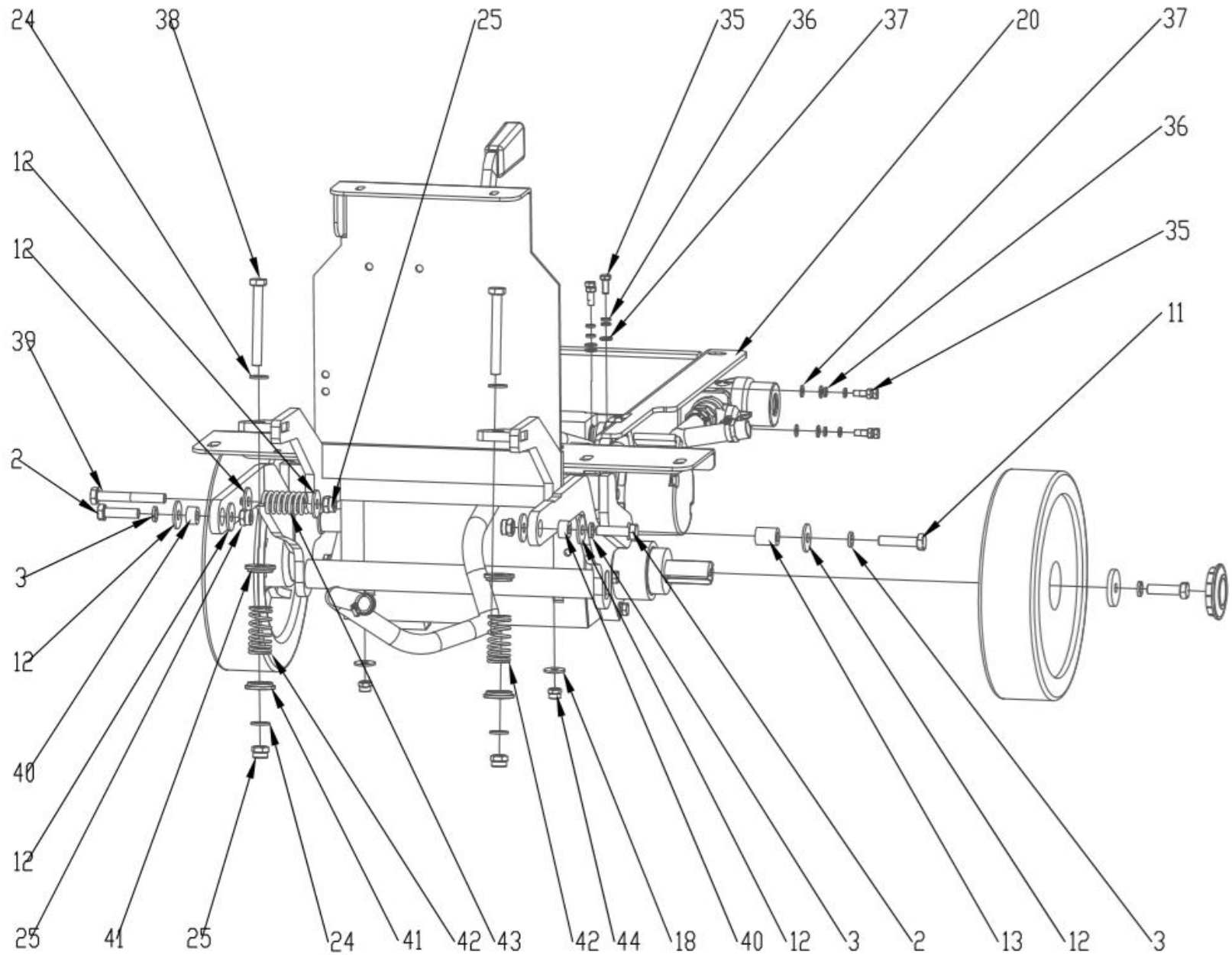



项目号 ITEM	零件号 P/N	名称	数量 QTY	DESCRIPTION
35	N010208	外六角 M5×12 不锈钢	4	SCREW M5×12 A2
36	N040023	弹垫 5 不锈钢	4	LOCK WASHER M5 A2
37	N030016	平垫 5×10×1 不锈钢	4	WASHER 5×10×1 A2
38	N010127	外六角 M8×70 不锈钢	2	SCREW M8×70 A2
39	N010092	外六角 M8×60 镀锌	1	SCREW M8×60 ZINC
40	B020001	铜套 8×15×8.5	2	BUSHING 8×15×8.5
41	B060121	压簧挡圈	4	SPRING SEEGER RING
42	B070052	压缩弹簧 Φ20×40, 线径 2	2	SPRING Φ20×40×2
43	B070026	压簧 Φ2.8XΦ20X38(7 圈)	1	SPRING Φ20×38×2.8
44	N020012	自锁螺母 M6 镀锌	2	LOCK NUT M6 ZINC

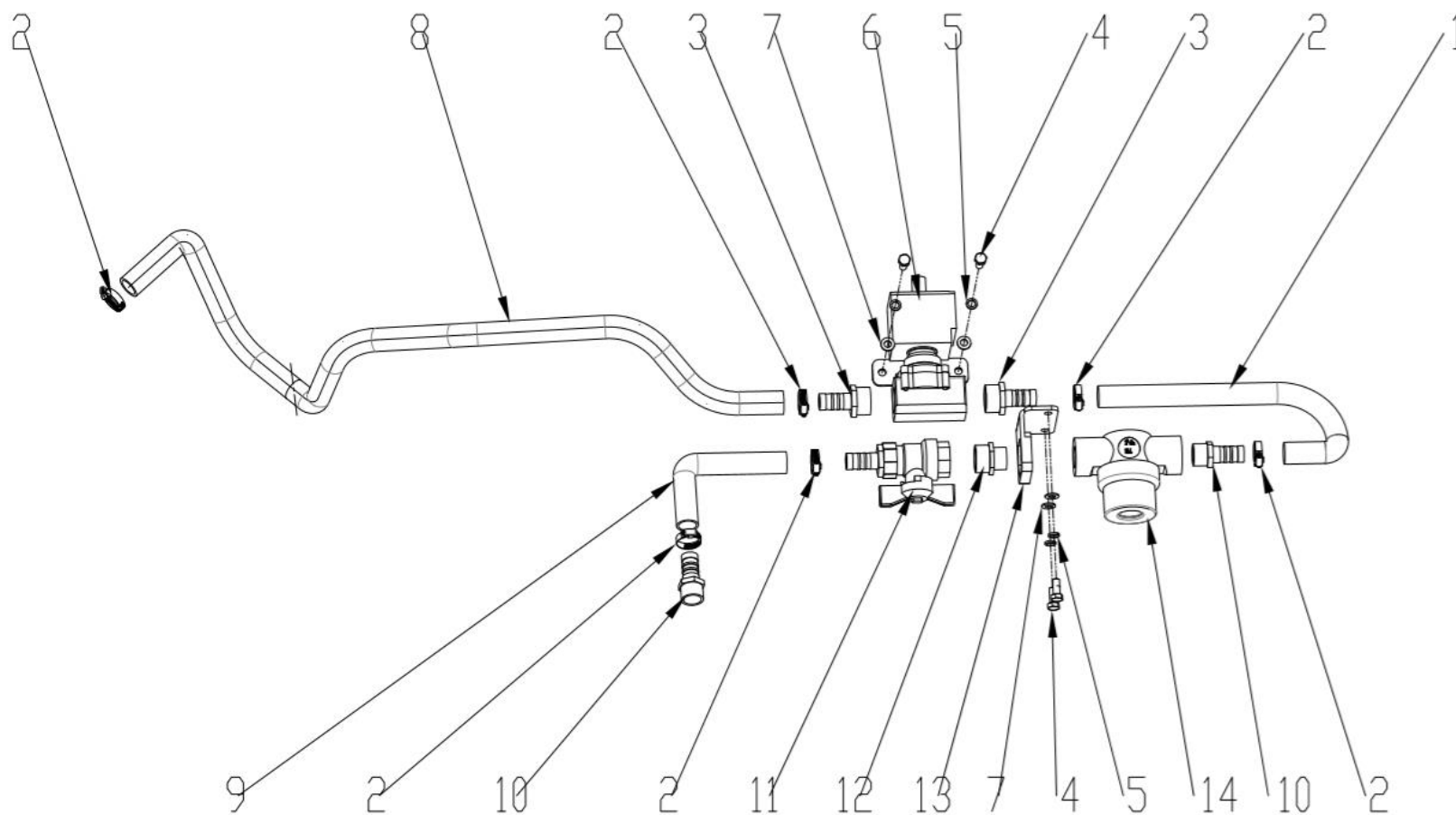

项目号 ITEM	零件号 P/N	名称	数量 QTY	DESCRIPTION
1	F050094	内嵌钢丝水管 D=18 d=13	0.25	STEEL PIPE D=18 D=13 L=250
2	F050007	卡箍 $\phi 8-16$	6	SCREW CLAMP $\Phi 8-16$
3	F020002	快速接头 二分之一	2	CONNECTOR 1/2
4	N010029	外六角 M5×16 不锈钢	4	SCREW M5×12 A2
5	N040023	弹垫 5 不锈钢	4	LOCK WASHER M5 A2
6	W020256	电磁阀组件2-T55-70BT	1	SOLENOID VALVE ASSEMBLY T55/70BT
7	N030016	平垫 5×10×1 不锈钢	4	WASHER 5×10×1 A2
8	F050094	内嵌钢丝水管 D=18 d=13	0.6	STEEL PIPE D=18 D=13 L=600
9	F050094	内嵌钢丝水管 D=18 d=13	0.1	STEEL PIPE D=18 D=13 L=100
10	F020003	快速接头 八分之三	2	CONNECTOR 3/8
11	F010006	蝶形球阀 二分之一 直接头 D=10	1	BALL VALVE 1/2 CONNECTION STRAIGHT D=10
12	F020019	外丝接头二分之一 3/8 不锈钢	1	CONNECTOR 1/2-3/8 A2
13	A030034	水阀支架	1	SUPPROT 35×43
14	F010004	过滤阀 八分之三	1	FILTER 3/8

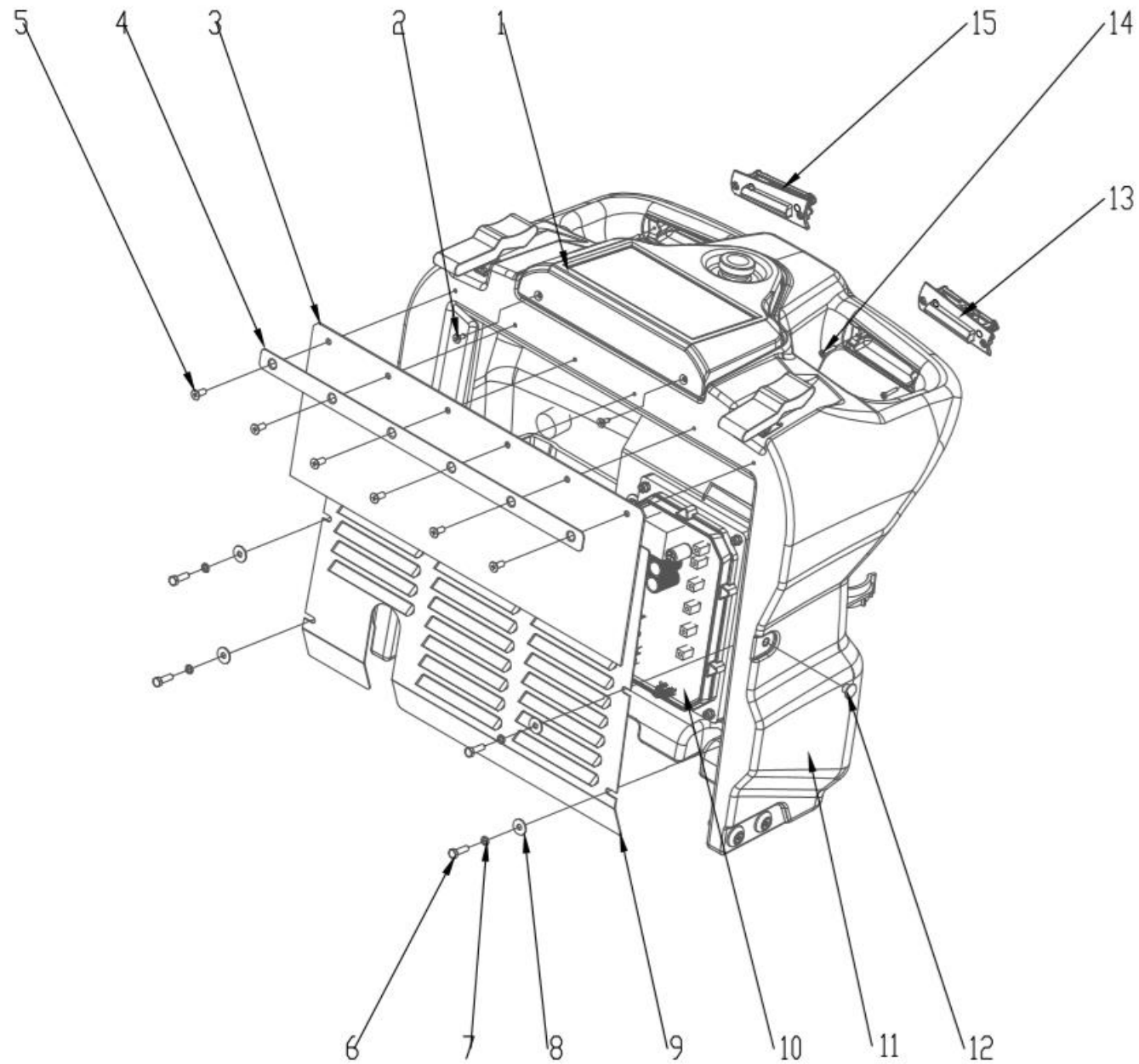

项目号 ITEM	零件号 P/N	名称	数量 QTY	DESCRIPTION
1	W010559	触摸屏控制面板组件	1	FLAT PANEL CONTROL ASSMBLY
2	N010111	沉头十字自攻螺丝 ST3.5×13 不锈钢	2	CORSS SCREW ST3.5×13 A2
3	B050027	手柄盒挡板 T70	1	BAFFLE
4	A060004	手柄盒橡胶压条 400x20	1	LAYERING 400×20
5	N010118	沉头内六角 M5×20 镀锌	6	CROSS SCREW M5×20 ZINC
6	N010029	外六角 M5×16 不锈钢	4	SCREW M5×16 A2
7	N040023	弹垫 5 不锈钢	4	LOCK WASHER M5 A2
8	N300040	大平垫 5×15×1 不锈钢	4	WASHER 5×15×1 A2
9	C020007	手柄盒盖板 T55	1	SUPPROT COVER
10	W010563	电路板支架组件	1	CIRCUIT BOARD ASSEMBLY
11	C010154	T55BT PRO 手柄盒绿色	1	HANDLE BOX YELLOW
12	N090025	孔堵头 Φ8	2	PIUG Φ8
13	W030112	驱动开关小组件 左	1	DRIVE SWITCH - LEFT
14	N010320	十字半圆头自攻螺丝 ST3.0×16-镀黑锌	4	SCREW ST3.0×16 BLACK ZINC
15	W030113	驱动开关小组件 右	1	DRIVE SWITCH - RIGHT

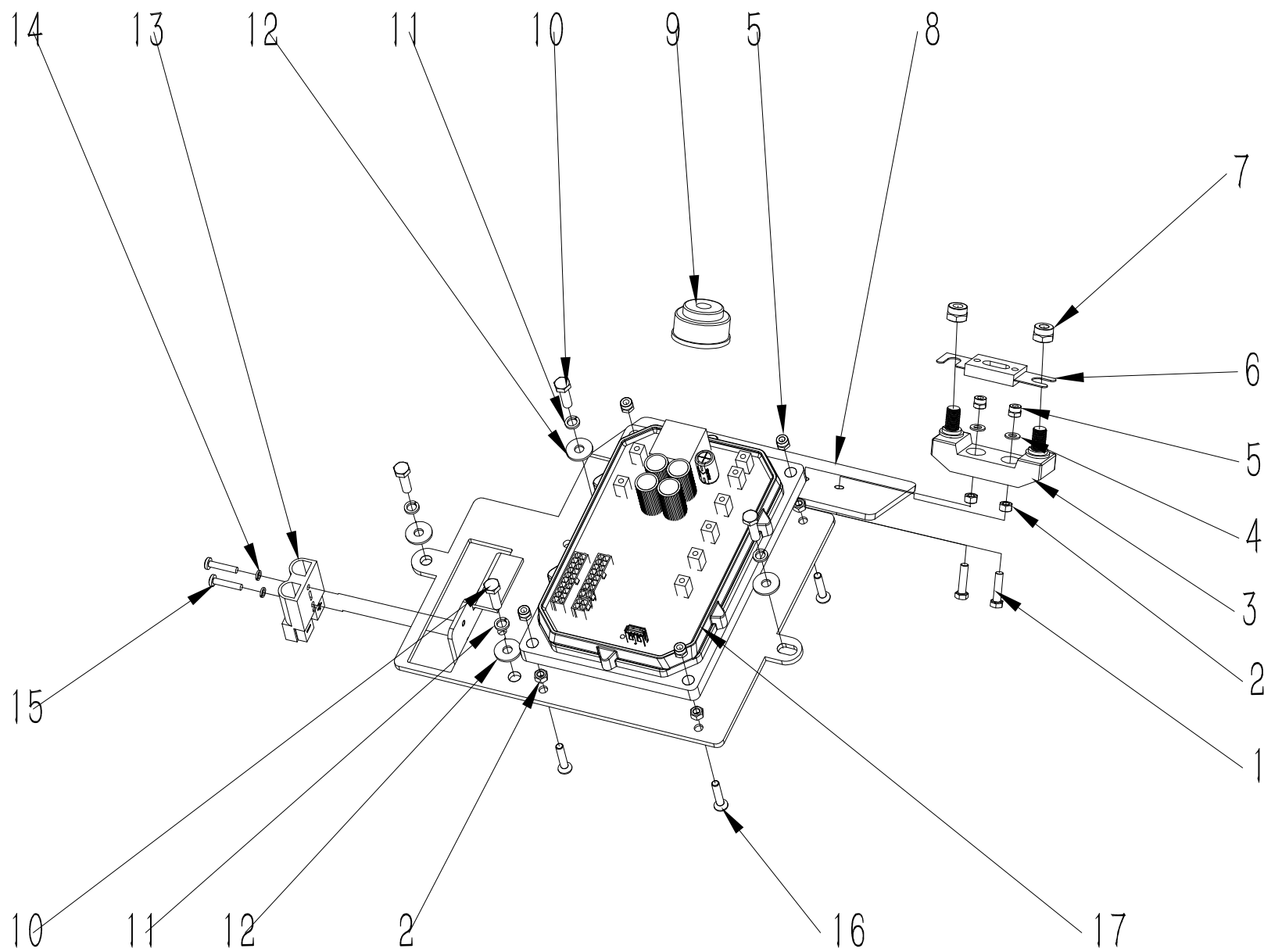

项目号 ITEM	零件号 P/N	名称	数量 QTY	DESCRIPTION
1	N010062	外六角 M5×20 镀锌	2	SCREW M5×20 ZINC
2	N020014	螺母 M5 镀锌	6	NUT M5 ZINC
3	E050004	陶瓷保险座 80A	1	FUSE HOLDER 80A
4	N030016	平垫 5×10×1 不锈钢	2	WASHER 5×10×1 A2
5	N020016	自锁螺母 M5 镀锌	6	LOCK NUT M5 ZINC
6	E050005	保险 22x80 80A	1	FUSE 80A
7	N020001	自锁螺母 M8 镀锌	2	LOCK NUT M8 ZINC
8	A040111	电路固定板	1	CIRCUIT BOARD SUPPORT
9	E050135	蜂鸣器 LZQ-2725A	1	BUZZER
10	N010006	外六角 M6×20 镀锌	4	SCREW M6×20 ZINC
11	N040001	弹垫 6 镀锌	4	LOCK WASHER M6 ZINC
12	N030008	大平垫 6×18×1.6 镀锌	4	WASHER 6×18×1.6 ZINC
13	E080149	线束 T55PRO	1	WIRE HARNESS
14	N040015	弹垫 4 镀锌	2	LOCK WASHER M4 ZINC
15	N010096	盘头十字螺钉 M4×20 不锈钢	2	SCREW M4×20 A2
16	N010066	沉头内六角 M5×25 不锈钢	4	CROSS SCREW M5×25 A2
17	W020406	控制器组件-大能-T55PRO	1	CONTROLLER ASSEMBLY DALA T55PRO



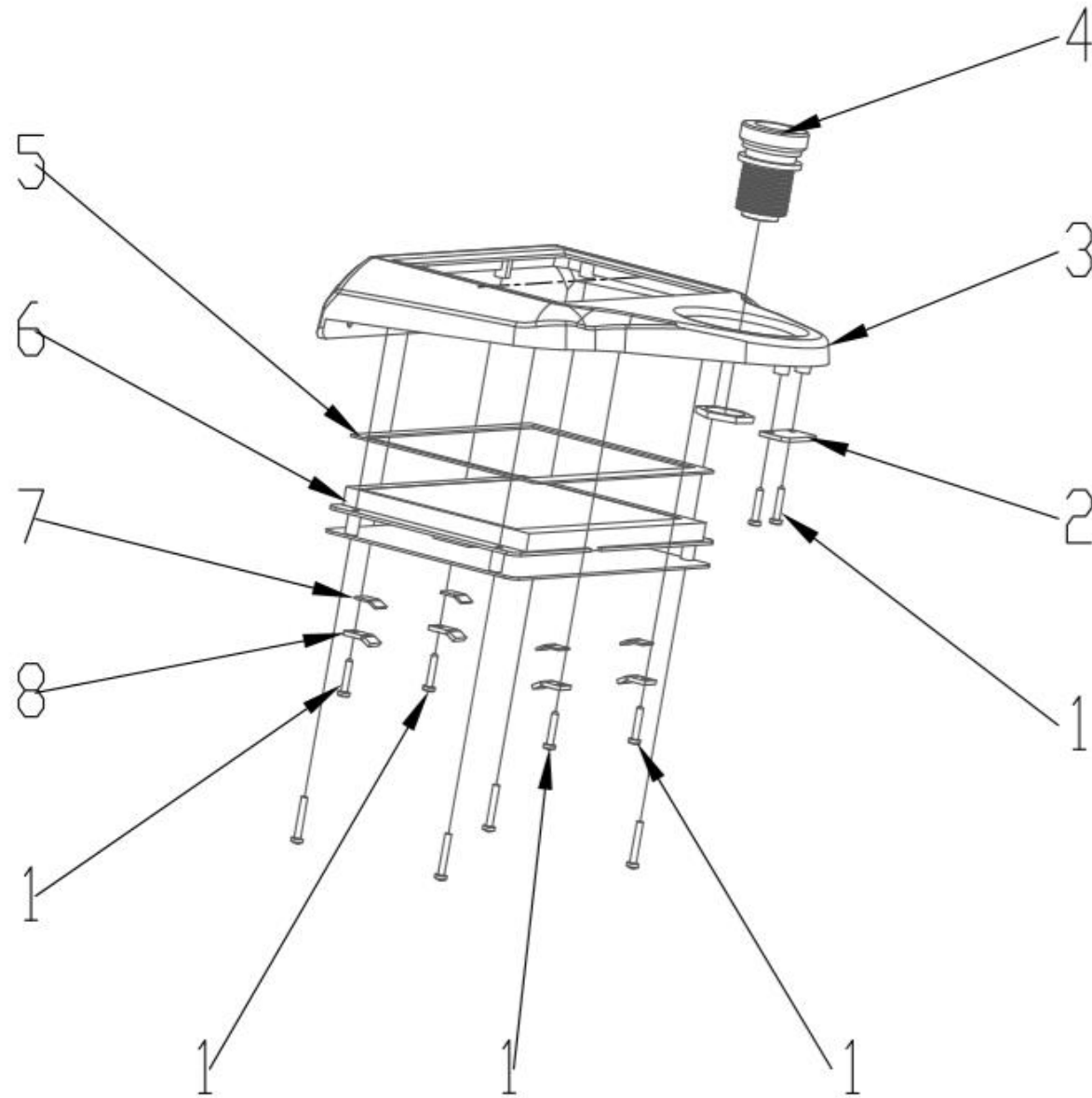

项目号 ITEM	零件号 P/N	名称	数量 QTY	DESCRIPTION
1	N010350	十字半圆头螺丝 M3.0×10-镀镍	6	SCREW M3×10 NICKEL
2	A040115	控制面板固定板	1	CONTROL PANEL FIXED PATE
3	C010141	T55PRO 控制面板	1	CONTROL PANEL
4	E020086A	急停开关 FM19N-SFP-11Z	1	EMERGENCY STOP FM19N-SFP-11Z
5	F040016	硅胶垫 168×103×1	1	SILICONE PAD 168×103×1
6	W020432	控制面板组件-大能-T55PRO-TVX	1	CONTROL PANEL ASSEMBLY DALA T55PRO TVX
7	F040017	硅胶垫宽 10, 厚 1, 3M 背胶	4	SILICONE PAD 10×1
8	A040118	触摸屏压板	4	TOUCH SCREEN PRESSURE PLATE

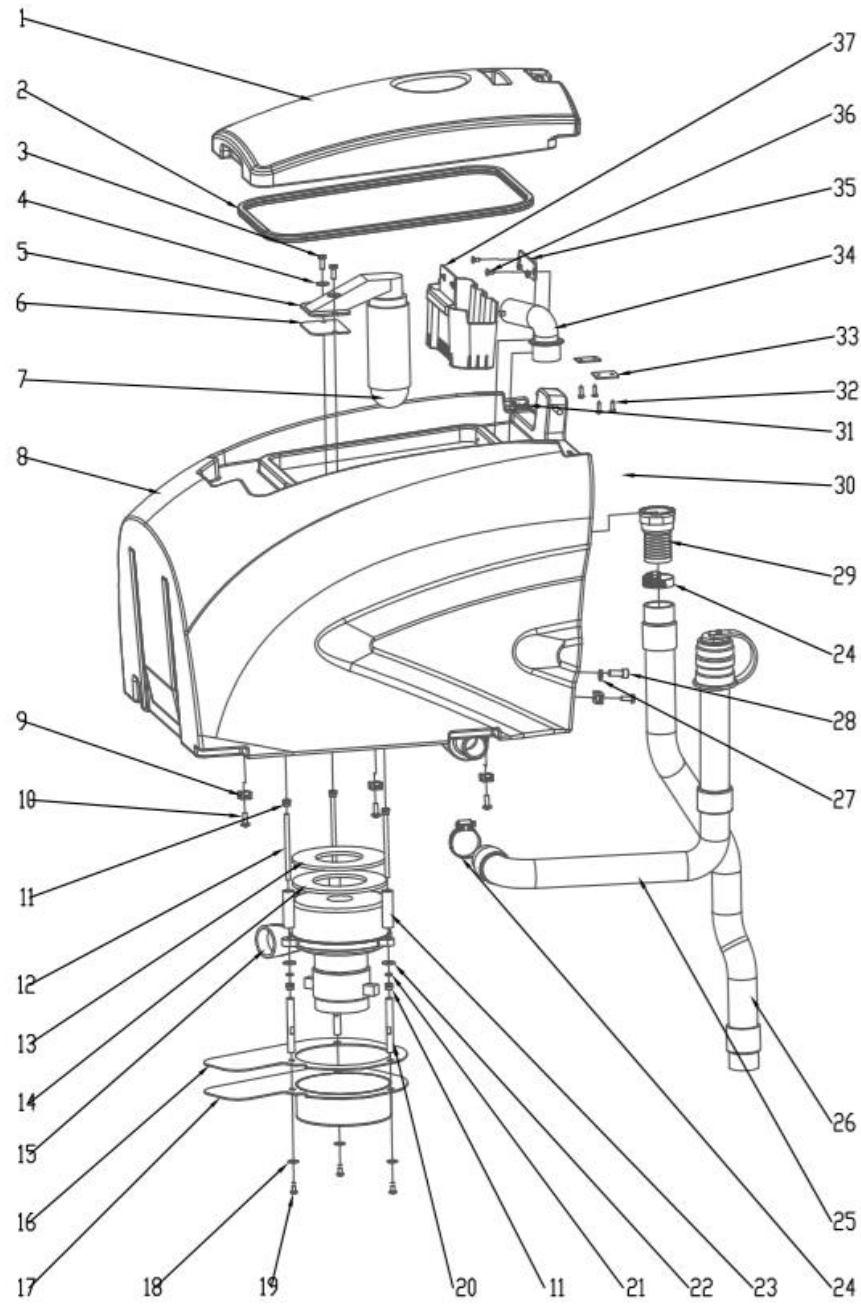

项目号 ITEM	零件号 P/N	名称	数量 QTY	DESCRIPTION
1	C010130	污水箱盖-带杯座	1	WASTEWATER TANK COVER WITH INNER GROOVE
2	N090010	密封条 19.5×9.5×9	1.28	RUBBER SEAL STRIP L=1280
3	N010226	外六角 M6×16 黑色 PP	2	SCREW M6×16 BLACK PP
4	N030022	大平垫 6×18×1.6 不锈钢	5	WASHER 6×18×1.6 A2
5	C020049	吸水口主体	1	SUCTION BODY
6	C030040	吸水口密封垫 T35	1	SUCTION GASKET
7	F040010	吸水口浮球 T35	1	SEWAGE TANK FLOAT FILTER
8	C010153	55L PRO 污水箱 绿色	1	RECOVERY TANK 55L GREEN
9	N090002	扎带固定座 23x16	4	SUPPORT 23×16
10	N010073	盘头十字螺钉 M5×16 镀锌	4	CROSS SCREW M5X16 ZINC
11	N020012	自锁螺母 M6 镀锌	6	LOCK NUT M6 ZINC
12	N100008	螺杆 M6x100mm	3	SCREW M6×100
13	F040001	真空泵消音垫 Φ140x5	1	SPONGE Φ140×5
14	F040005	3M 背胶	1	3M ADHESIVES GUM
15	W020252	吸水电机组件	1	VACUUM MOTOR ASSEMBLY 24V 390W
16	C020105	隔音棉 T55	1	SOUNDPROOF COTTON
17	A040083	消音盖板 T55	1	MUFFLER COVER
18	N030040	平垫 5×15×1 不锈钢	3	WASGER 5×15×1 A2
19	N010112	盘头十字螺钉 M5×16 不锈钢	3	CORSS SCREW M5×16 A2
20	B020035	铜螺柱 L=82	3	COPPER STUD L=82
21	N040001	弹垫 6 镀锌	3	LOCK WASHER M6 ZINC
22	N030008	大平垫 6x18x1.6 镀锌	3	WASHER 6×18×1.6 ZINC
23	B050029	支撑套管 55	3	SLEEVING
24	F050006	卡箍 φ33-57	2	SCREW CLAMP Φ33-57
25	F060001	排污管 D.38x800	1	DRAINAGE PIPE D38×800
26	F060002	吸污管 D.38x1100	1	SUCTION HOSE D38×1250

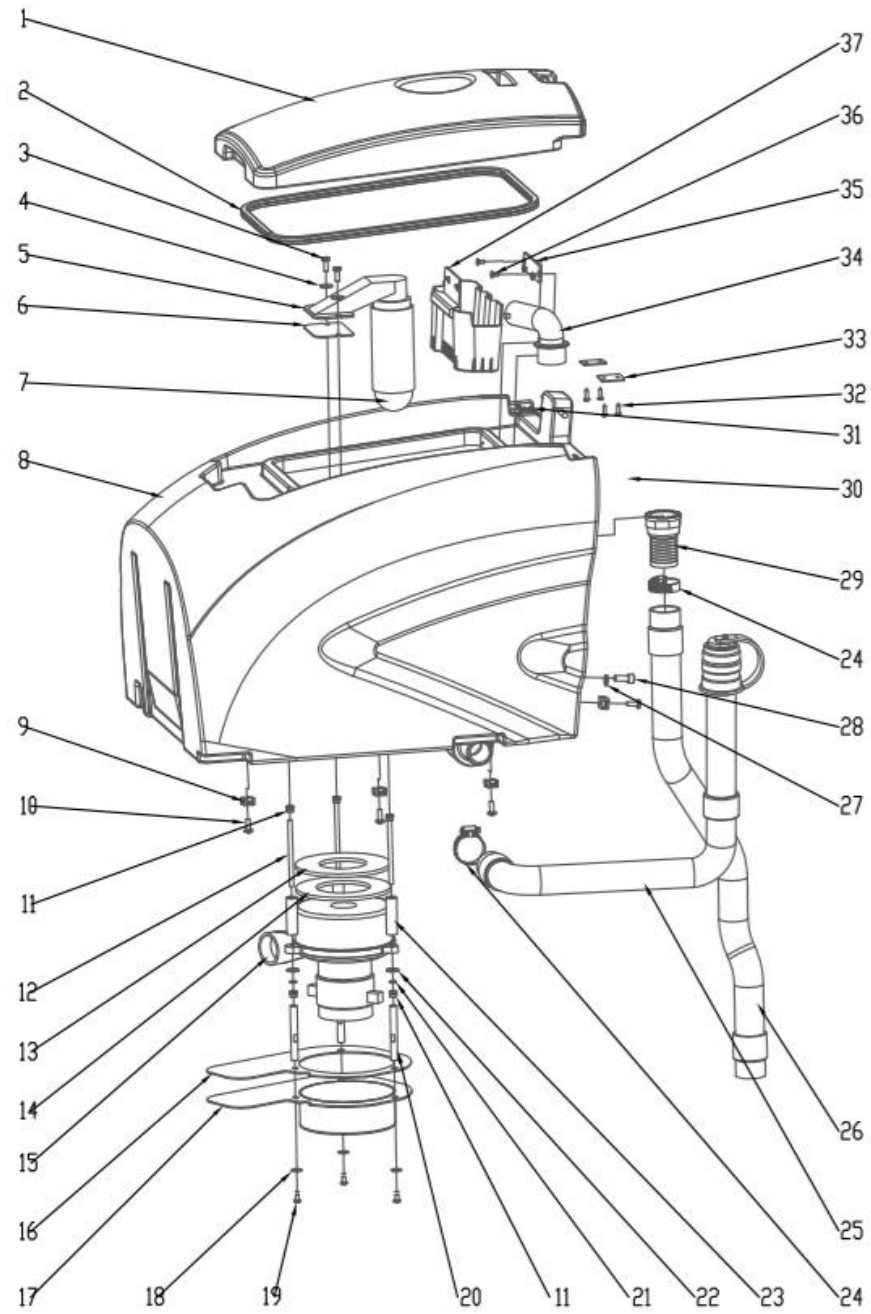

项目号 ITEM	零件号 P/N	名称	数量 QTY	DESCRIPTION
27	N030010	平垫 8x16x1.6 不锈钢	1	WASHER 8×16×1.6 A2
28	N010040	内六角圆柱头 M8×20 不锈钢	1	SCREW M8×20 A2
29	C020009	污水进水口直接头 D38	1	CONNERCTOR STRAIGHT D38
30	B060031	污水箱拉线 L=445mm	1	CABLE L=445
31	N010052	十字槽盘头自攻螺钉 ST4.2×16 不锈钢	4	SCREW ST4.2×16 A2
32	N010052	盘头十字自攻螺丝 ST4.2×16 不锈钢	4	CORSS SCREW ST4.2×16 A2
33	A010001	箱盖固定板 34x30	2	PLAQUE 34×30
34	C020008	污水进水口弯头 D35	1	CONNECTOR REND D38
35	A040107	过滤篮固定座	1	FILTER BASKET HOLDER 100×25×3 A2
36	N010097	沉头十字自攻螺丝 ST4.2x13 不锈钢	2	SCREW ST4.2×13A2
37	C020087	一级过滤器 T130	1	PRIMARY FILTER

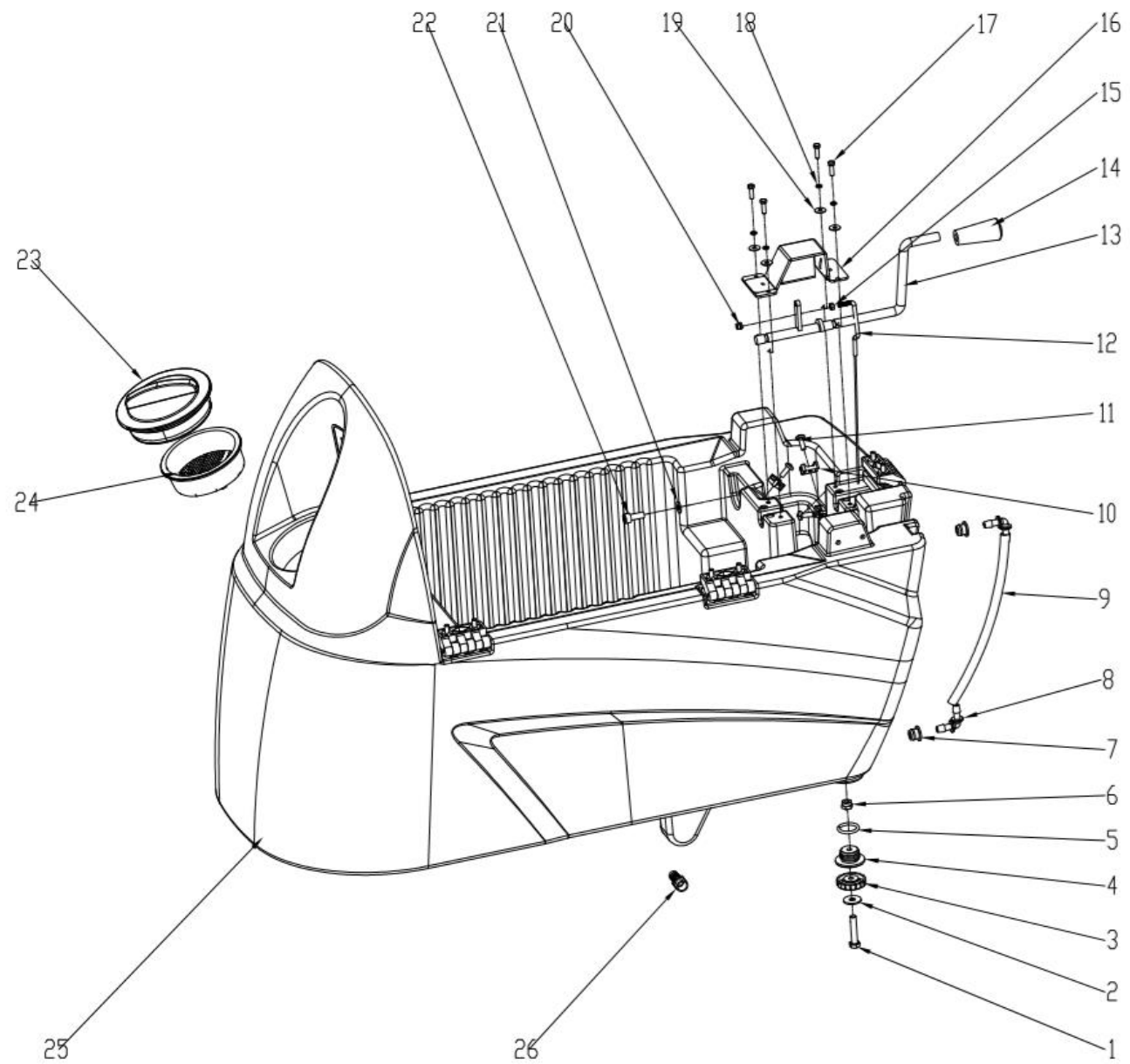



项目号 ITEM	零件号 P/N	名称	数量 QTY	DESCRIPTION
1	N010068	外六角 M8X40 不锈钢	1	SCREW M8×40 A2
2	N030028	平垫 8x24x2 不锈钢	1	WASHER 8×24×2 A2
3	N020009	花型螺母 M8	1	NUT M8
4	B020006	四分之三 堵头	1	PLUG 3/4
5	N090046	O 型密封圈 $\phi 23$ (内径) $\times \phi 3.5$ (线径)	1	O RING $\phi 34 \times \phi 5$
6	N020024	自锁螺母 M8 不锈钢	1	LOCK NUT M8 A2
7	C030013	标识密封垫 $\phi 8$	2	GASKET $\phi 8$
8	F020001	快速接头 $\phi(8-6) \times 30$	2	CONNECTOR $\phi(8-6) \times 30$
9	F050032	PVC-水管-D=8-d=6	0.27	WATER LEVEL TUEE
10	N090002	扎带固定座 23x16	3	SUPPORT 23×16
11	N010073	盘头十字螺钉 M5×16 镀锌	3	CROSS SCREW M5X16 ZINC
12	B060034	扒头拉线 L=355	1	CABLE L=355
13	A050020	提升操纵杆 M12	1	LEVER
14	N100007	提升摇臂把手 M12	1	HANDLE M12
15	N020014	螺母 M5 镀锌	1	NUT M5 ZINC
16	A050021	提升开关支架 95	1	SUPPORT
17	N010025	外六角 M5×16 镀锌	4	SCREW M5×16 ZINC
18	N040007	弹垫 5 镀锌	4	LOCK WASHER M5 ZINC
19	N030054	大平垫 5×15×1 镀锌	4	WASHER 5×15×1 ZINC
20	N020016	自锁螺母 M5 镀锌	1	LOCK NUT M5 ZINC
21	N030010	平垫 8x16x1.6 不锈钢	1	WASHER 8×16×1.6 A2
22	N010040	内六角圆柱头 M8×20 不锈钢	1	SCREW M8×20 A2
23	C020005	清水箱注水口盖子 $\phi 115$ 螺纹	1	THREADED COVER $\phi 115$
24	C020006	清水箱注水口滤网 $\phi 110$	1	FILTER $\phi 110$
25	C010152	55L PRO 清水箱	1	SOLUTION TANK 55L GREEN
26	F020003	快速接头 八分之三	1	CONNECTOR 3/8

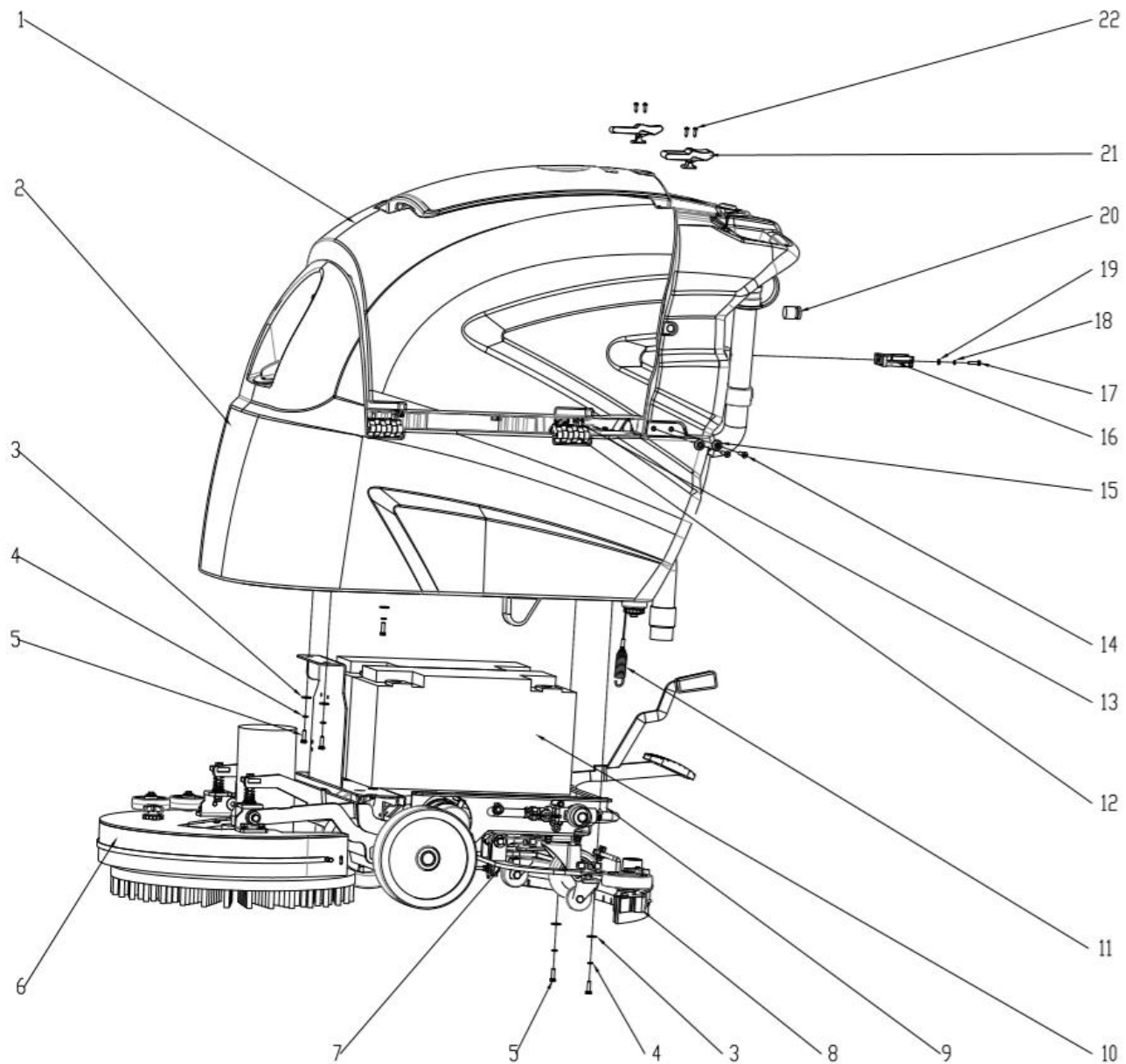

项目号 ITEM	零件号 P/N	名称	数量 QTY	DESCRIPTION
1	W010580	污水箱组件 T55 PRO	1	RECOVERY TANK ASSEMBLY
2	C010152	清水箱 T55 PRO	1	SOLUTION TANK
3	N030008	平垫-6×18×1.6-镀锌	6	WASHER 6×18×1.6 ZINC
4	N040001	弹垫-M6-镀锌	6	LOCK WASHER M6 ZINC
5	N010006	外六角-M6×20-镀锌	6	SCREW M6×20 ZINC
6	W010557	机头组件	1	NOSE ASSEMBLY
7	W010063	扒头支架组件	1	SQUEEGEE SUPPORT ASSEMBLY
8	W010569	扒头组件 760 黑色	1	SQUEEGEE ASSEMBLY BLACK
9	W010556	底座架组件	1	FRAME ASSEMBLY
10	E040230	理士电池 LDC12-140	2	BATTERY 12V 120Ah
11	B070017	单向拉簧 3×20×75.4	1	SPRING 3×20×75.4
12	C020011	合页 40×14	3	HINGE 40×14
13	N010017	沉头内六角-M6×25-镀黑锌	12	SCREW M6×25 BLCK ZINC
14	N010361	沉头十字-M6×35-镀黑锌	4	SCREW M6×35 BLCK ZINC
15	C020028	异性垫片 Φ5	4	WASHER Φ5
16	C020265	加强管托	1	SCREW CLAMP
17	N010135	外六角-M5×20-不锈钢	1	SCREW M5×20 A2
18	N040023	弹垫-M5-不锈钢	1	LOCK WASHER M5
19	N030016	平垫-5×10×1-不锈钢	1	WASHER 5×15×1 A2
20	E020084	自复位按键 FM22N-SFP-11D1S1/g23	1	SWITCH
21	N090004	橡胶塔扣 50	2	RUBBER HASP
22	N010052	圆头十字自攻螺丝-4.2×16-不锈钢	4	SCREW 4.2×16 A2

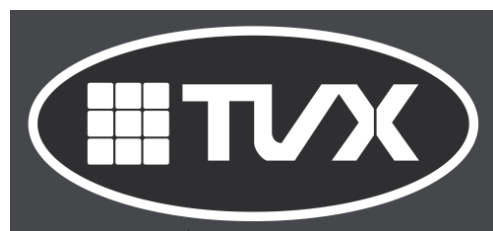

1

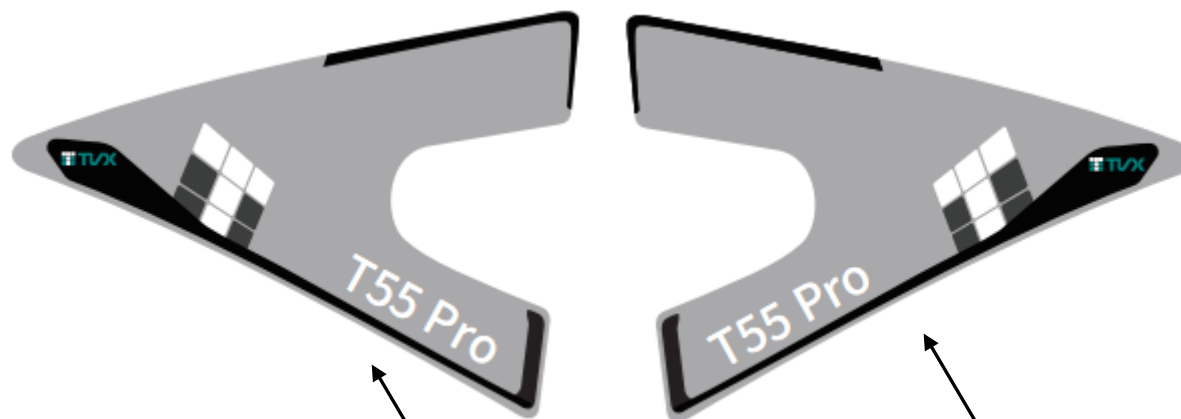

2

3



4



5

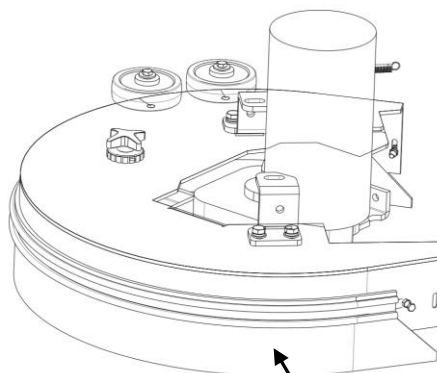

6

项目号 ITEM	零件号 P/N	名称	数量 QTY	DESCRIPTION
1	C040367	TVX 前标-灰底银拉丝	1	TVX LABEL
2	C040446	T55PRO 右侧灰色标贴	1	FRONT-LEFT-RIGHT LABEL
3	C040445	T55PRO 左侧灰色标贴	1	SIDE MODEL LABEL
4	C040025	提升摇臂标识	1	LEVER LABEL
5	C040371	档位铭牌	1	GEAR LABEL
6	C030007	刷盘防溅条	1	RUBBER SKIRT 85x1190
7	M010015	塑料包装袋 1400x700x1000	1	PLASTIC BAG 1400x700x1000
8	M020047	木托盘 T55PRO	1	WOODEN PALLETS 1360x620x130
9	M020008	三角挡块 50x50x100	4	TRIANGULAR BLOCK 50x50x100
10	M010002	纸箱上盖 T55 1380x660x100	1	CARTON 1380x660x100
11	M010001	纸箱 T55 1360x620x1045	1	CARTON COVER
12	M010009	纸盒扒头 760 820x270x120	1	760 SQUEEGEE CARTON BOX 820x275x120
13	M010014	说明书自封袋 340x240mm	1	ZIPLOCK 340x240mm
14	M020006	木条 T55 40x40x1020	4	BATTEN 55/70L 40X40X1020
15	M020007	支撑护角 50x50x100	12	SUPPORTING CORNER
16	P010004	保修卡	1	WARRANTY CARD
17	P010012	测试报告	1	TEST REPORT
18	P010144	T55BT PRO 说明书-TVX-英文	1	SYNOPSIS
19	W020011	电源连接线 500	1	POWER CABLE 500
20	W020008	电池短接线 500	1	BATTERY CABLE 500
21	N090031	钥匙挂件	2	KEY PENDANT

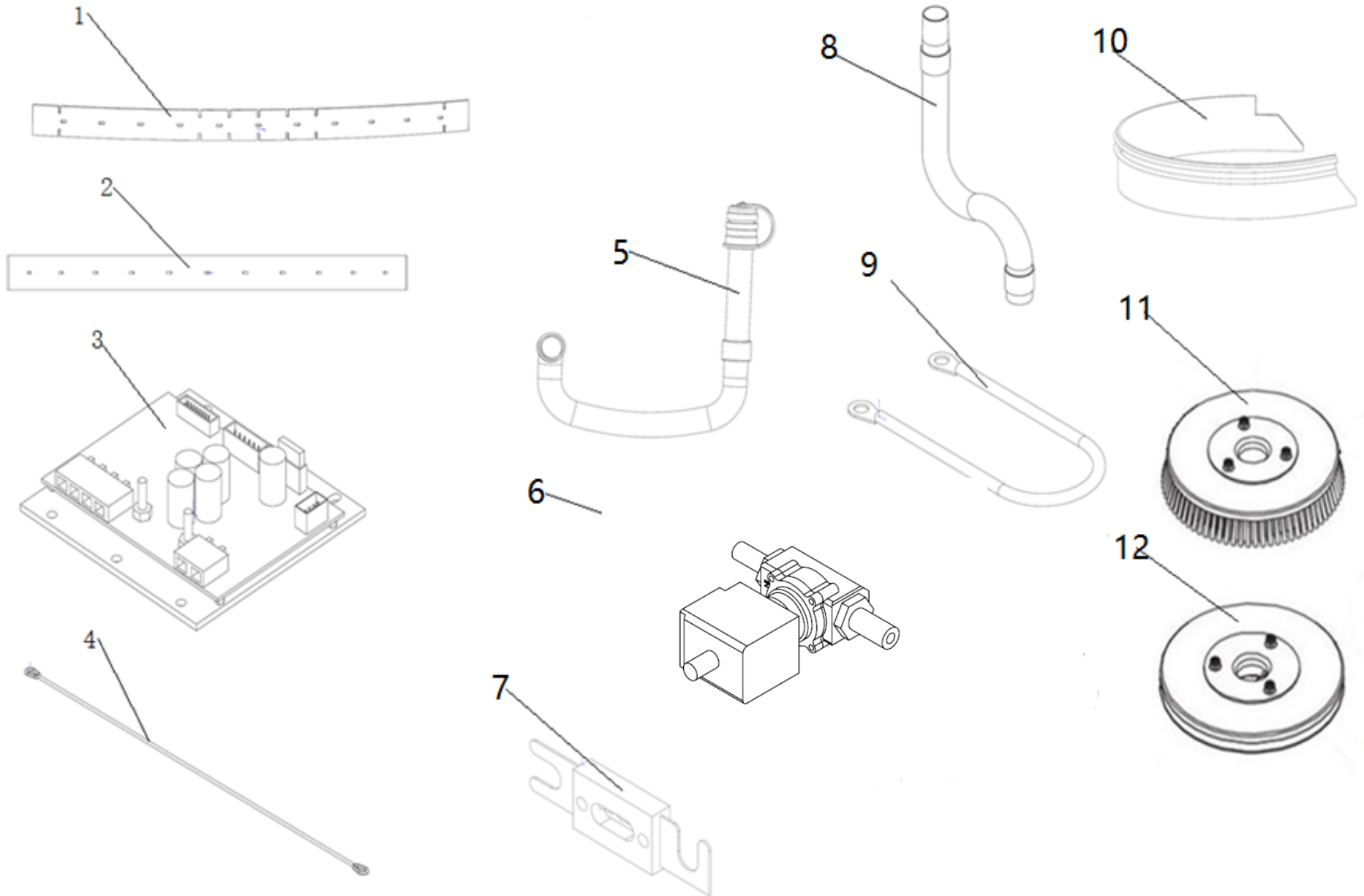

项目号 ITEM	零件号 P/N	名称	DESCRIPTION
1	C030014LTX	前刮皮-橡皮-3×50×785	FRONT SQUEEGE BLADE RUBBER LINATEX 3x50x785
2	C030015LTX	后刮皮-橡皮-4.5×53×835	REAR SQUEEGE BLADE RUBBER LINATEX 4.5x53x835
3	W020406	控制器组件-大能-T55PRO	CONTROLLER ASSEMBLY DALA T55PRO
4	B060034	扒头拉线 L=355	CABLE L=355
5	F060001	排污管 D38×800	SEWAGE PIPE D.38x800
6	W020256	电磁阀组件2-T55-70BT	SOLENOID VALVE ASSEMBLY T55/70BT
7	E050005	保险 22×80 80A	FUSE 80A
8	F060001	吸污管 D38×1100	SUCTIONHOUSE D.38x1100
9	W020008	电池短接线 500	BATTERY CABLE 500
10	C030007	刷盘防溅条	RUBBER SKIRT 85x1190
11	N150001	19" 刷盘	BRUSH-PPL0.6 19"
12	N150004	19" 针盘	PAD HOLDER 19"
1	C030014PU	前刮皮-橡皮-3×50×785	FRONT SQUEEGE BLADE RUBBER PU 3x50x785
2	C030015PU	-	REAR SQUEEGE BLADE RUBBER PU 4.5x53x835
11	N150045	19" 刷盘	BRUSH WATER LOCK 19" 0.5MM