



— **SCHEMATIC DRAWINGS** —

装配示意图

手推式洗地机 T70 / 65 BT+ (双)

Scrubber Dryer T70 / 65 BT+ (D)

Issued in Aug. 2023

Version: V11



目 录

1. 机头组件	1—4
2. 底座架组件	5—10
3. 扒头组件	11—12
4. 扒头支架组件	13—14
5. 水路组件	15—16
6. 手柄盒组件	17—24
7. 控制面板组件	25—26
8. 污水箱组件	27—30
9. 水箱体组件	31—32
10. 整机组件	33—34
11. 包装组件	35—36

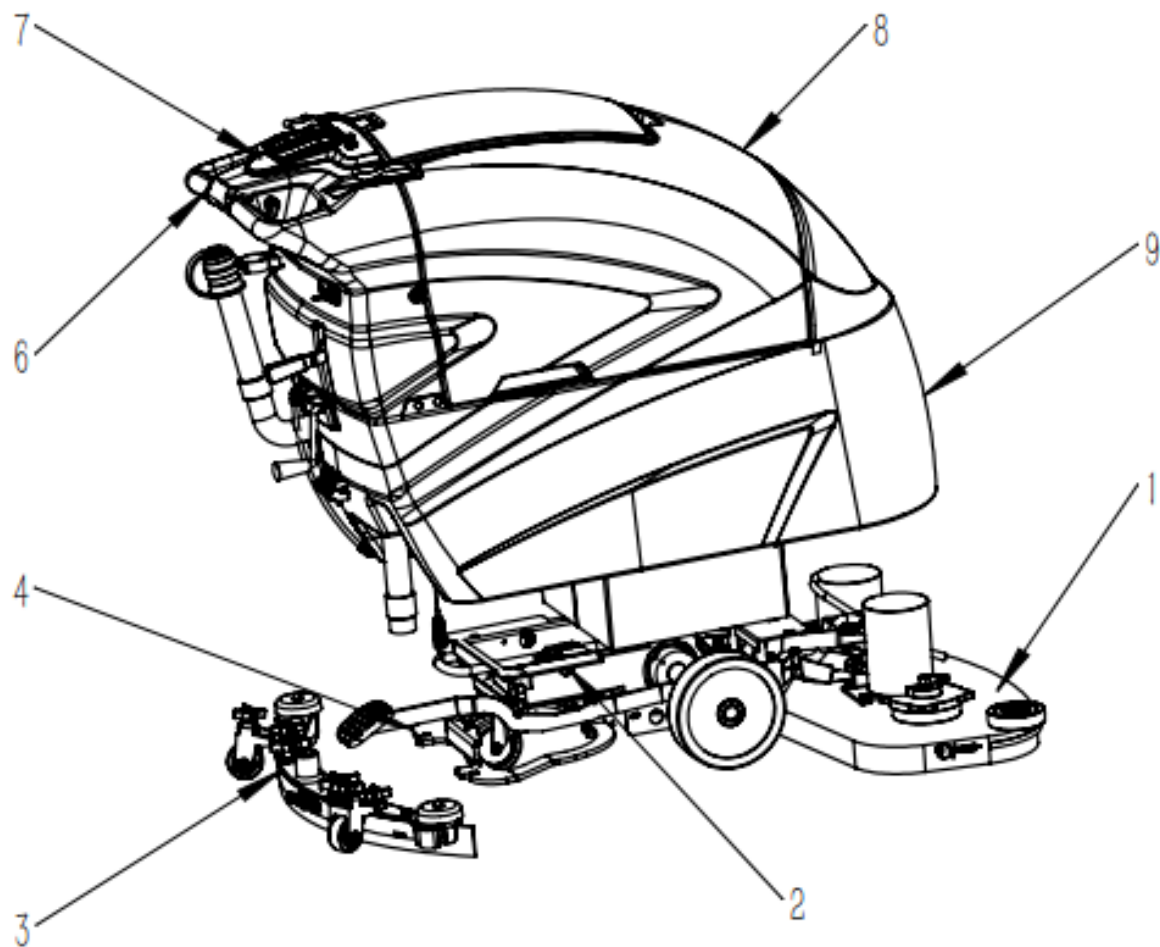

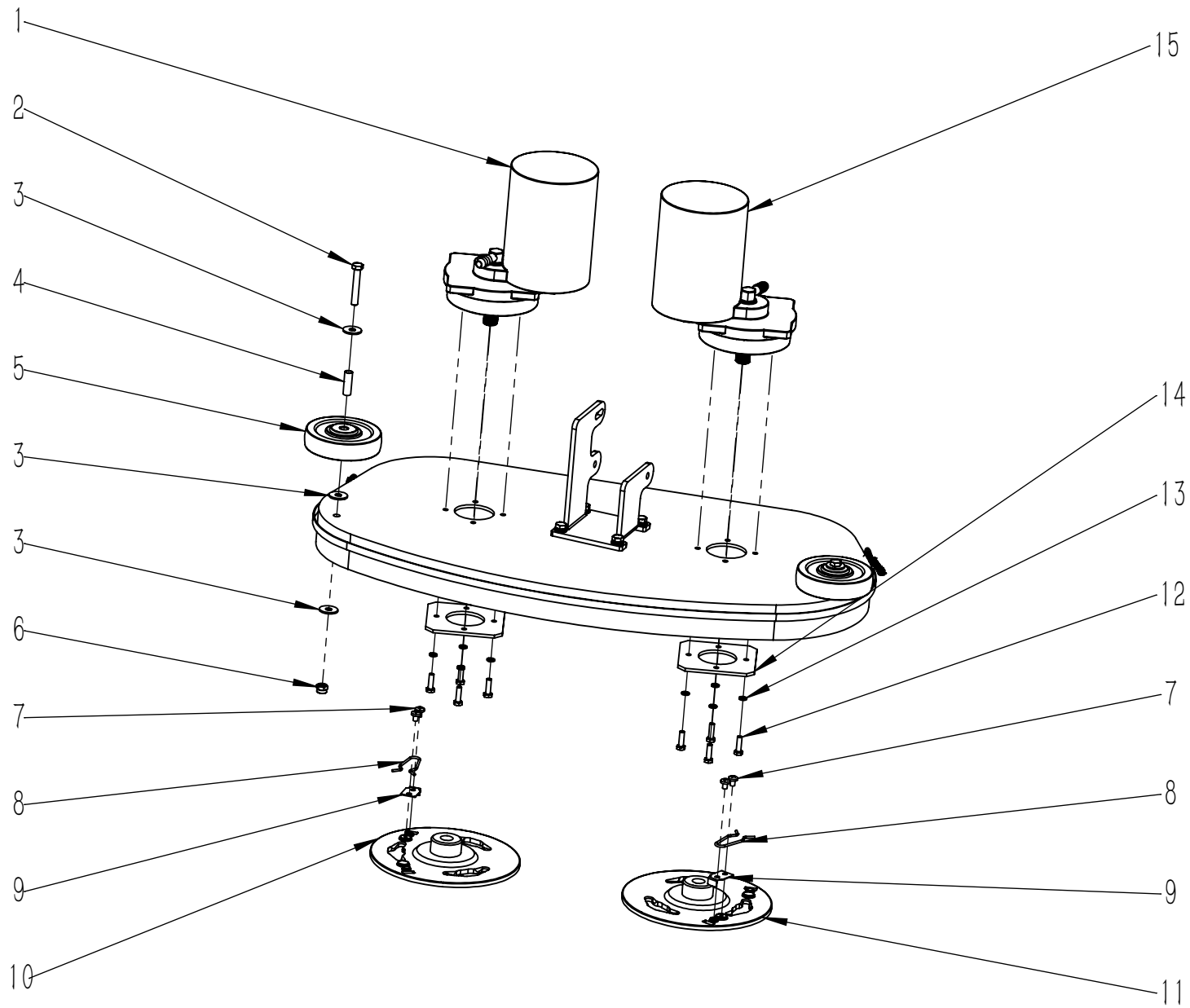

项目号 ITEM	零件号 P/N	数量 QTY	名称	DESCRIPTION
1	W020265	1	右刷盘电机组件	RIGHT BRUSH MOTOR ASSEMBLY 24V 400W
2	N010144	2	外六角-M8x50-不锈钢	SCREW M8x50 A2
3	N030028	6	平垫-8x24x2-不锈钢	WASHER 8x24x2 A2
4	B020027	2	防撞轮铜套 8x10x31	BUSHING 8x10x31
5	N110019	2	防撞轮 D100x29.5	WHEEL Φ100x29.5
6	N020024	2	自锁螺母-M8-不锈钢	LOCK NUT M8 A2
7	N010179	4	十字盘头-M5x8-不锈钢	SCREW M5x8 A2
8	B060122	2	刷盘锁紧器弹簧 D2	LOCKING SPRING Φ2
9	A040060	2	弹簧锁紧板	SPRING LOCKING PLATE
10	D010024	1	刷盘锁紧器-左	BRUSH PLATE-LEFT
11	D010025	1	刷盘锁紧器-右	BRUSH PLATE-RIGHT
12	N010006	8	外六角-M6x20-镀锌	SCREW M6x20 ZINC
13	N040001	8	弹垫-M6-镀锌	LOCK WASHER M6 ZINC
14	A040065	2	电机固定板	MOTOR PLATE
15	W020266	1	左刷盘电机组件	LEFT BRUSH MOTOR ASSEMBLY 24V 400W

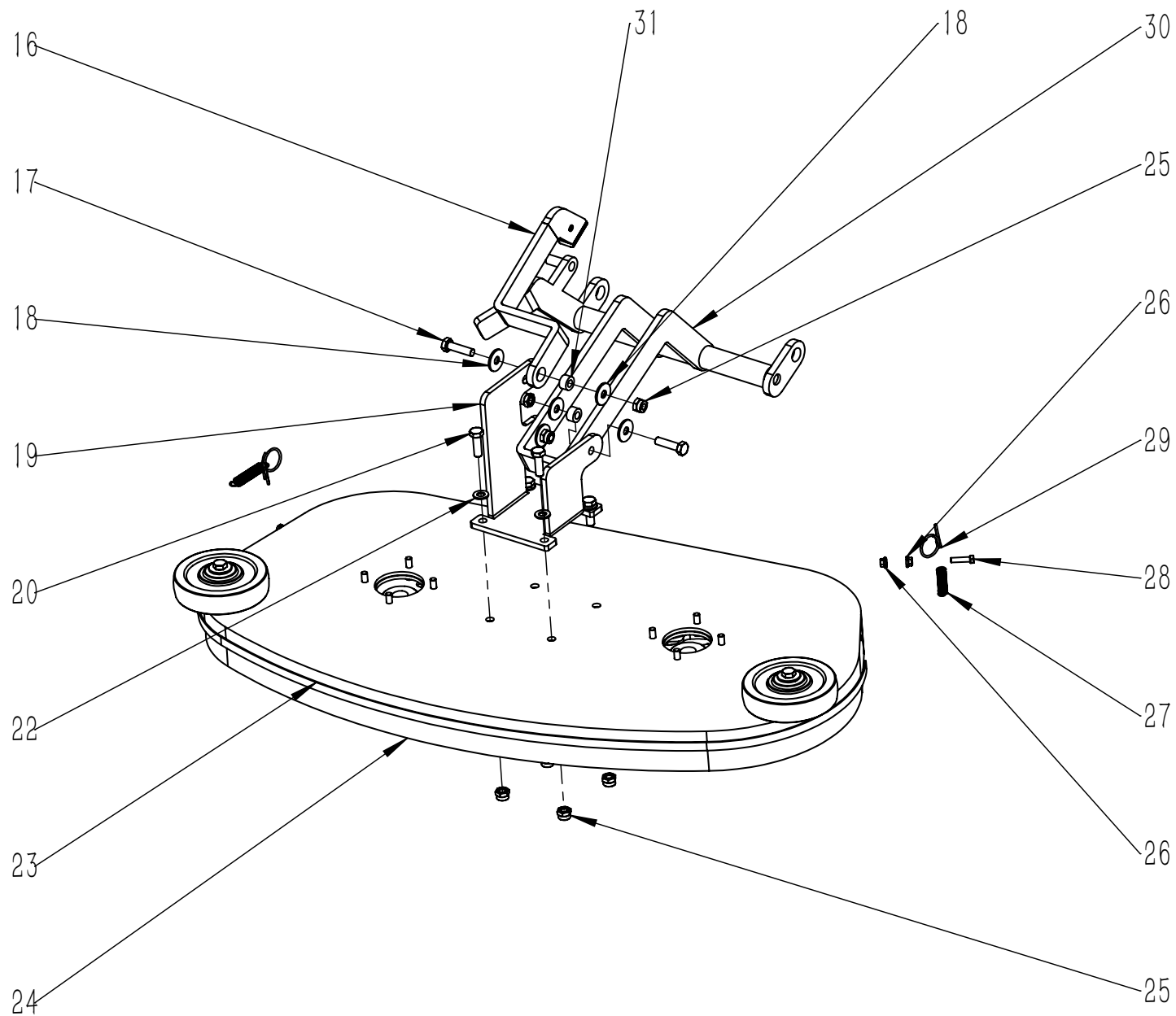

项目号 ITEM	零件号 P/N	数量 QTY	名称	DESCRIPTION
16	A040066	1	机头连接臂上	CONNECTING ARM OF MACHINE HEAD
17	N010002	3	外六角-M8x30-镀锌	SCREW M8x30 ZINC
18	N030027	6	平垫-8x24x2-镀锌	WASHER 8x24x2 ZINC
19	A040068	1	机头支座连接板	HEAD SUPPORT CONNECTION
20	N010007	4	外六角-M8x25-镀锌	SCREW M8x25 ZINC
22	N030006	4	平垫-8x16x1.6-镀锌	WASHER 8x16x1.6 ZINC
23	A040069	1	防溅条紧固钢条 10x1170	STEEL BAR 10x1170
24	A040067	1	机头底板	HEAD FLOOR
25	N020001	7	自锁螺母-M8-镀锌	LOCK NUT M8 ZINC
26	N020004	4	法兰面螺母-M5-镀锌	NUT M5 ZINC
27	B060012	2	钢条拉簧 1.1x10x55	SPRING 1.1x10x55
28	N010062	2	外六角-M5x20-镀锌	SCREW M5x20 ZINC
29	B070010	2	异型套圈 2x26	RING 2x26
30	A040064	1	机头连接臂	NOSE CONNECTING ARM
31	B020001	3	铜套 8x15x8.5	BUSHING 8x15x8.5

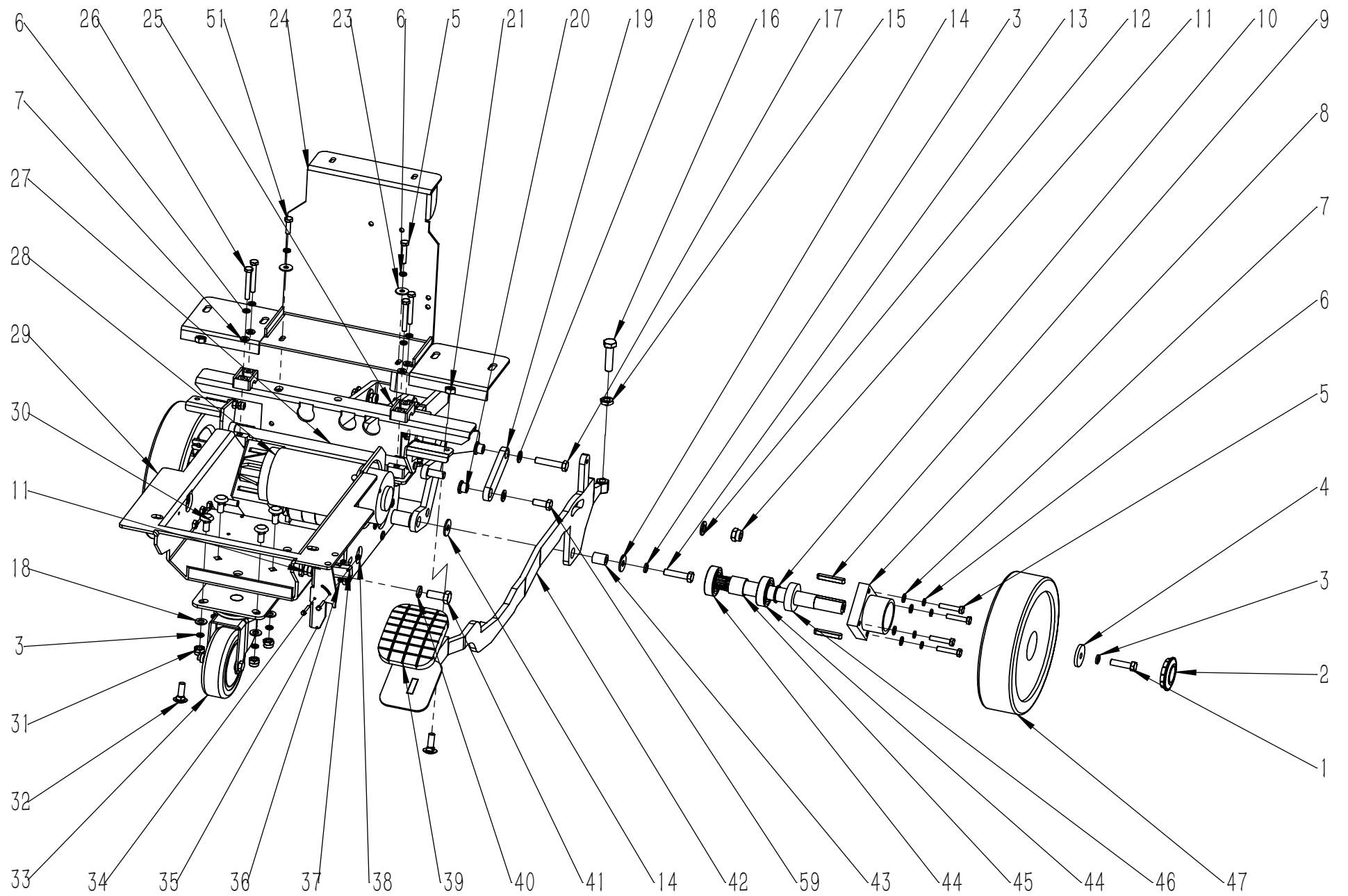

项目号 ITEM	零件号 P/N	数量 QTY	名称	DESCRIPTION
1	N010002	2	外六角-M8x30-镀锌	SCREW M8x30 ZINC
2	C020036	2	脚轮盖 D50	COVER Φ 50
3	N040013	8	弹垫-M8-镀锌	LOCK WASHER M8 ZINC
4	B060069	2	平垫-8.5x30x4-镀锌	WASHER 8.5x30x4 ZINC
5	N010033	9	外六角-M6x30-镀锌	SCREW M6x30 ZINC
6	N040001	14	弹垫-M6-镀锌	LOCK WASHER M6 ZINC
7	N030007	12	平垫-6x12x1.6-镀锌	WASHER 6x12x1.6 ZINC
8	D010010	2	轴承座 D70	BEARING SUPPORT Φ 70
9	N060001	4	平键 6x40	FLAT KEY 6x40
10	B060026	2	驱动轴 D20x185	AXLE SHAFT Φ 20x185
11	N020002	2	自锁螺母-M10-镀锌	LOCK NUT M10 ZINC
12	N030004	1	平垫-10x20x2-镀锌	WASHER 10x20x2 ZINC
13	N010008	1	外六角-M8x35-镀锌	SCREW M8x35 ZINC
14	N030027	5	平垫-8x24x2-镀锌	WASHER 8x24x2 ZINC
15	N020053	1	六角薄螺母-M10-镀锌	NUT M10 ZINC
16	N010026	1	外六角-M10x40-镀锌	SCREW M10x40 ZINC
17	N010043	1	外六角-M8x40-镀锌	SCREW M8x40 ZINC
18	N030006	7	平垫-8x16x1.6-镀锌	WASHER 8x16x1.6 ZINC
19	A040010	1	连接板 24x70	PLAQUE 24x70
20	B020005	2	铜套 8x(18-13)x10.5	BUSHING 8x(18-13)x10.5
21	N020018	5	螺母-M8-镀锌	NUT M8 ZINC
23	N030008	3	平垫-6x18x1.6-镀锌	WASHER 6x18x1.6 ZINC
24	A030003	1	电瓶挡板 448	SPLASH GUARD 448
25	C020002	4	哈氟块 23	HOLDFAST 23
26	N010114	4	外六角-M6x45-镀锌	SCREW M6x45 ZINC
27	A030001	1	刹车连杆 265	ROCKER ARM 265
28	W020263	1	驱动电机组件	DRIVE MOTOR ASSEMBLY 24V 120W 105RPM
29	A030002	1	底座架-450x222-T55-70BT	FRAME 450x222 T55/70BT

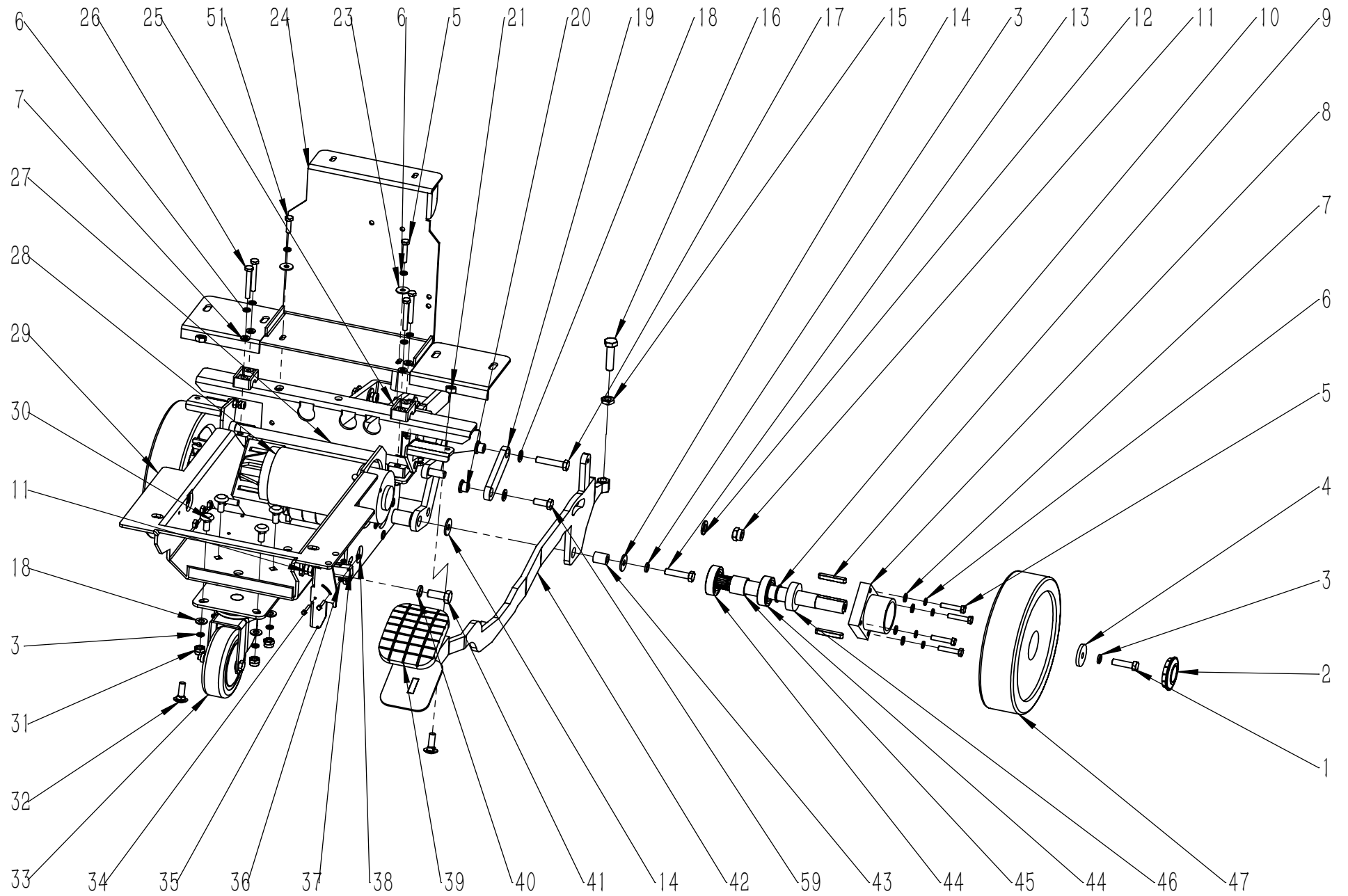

项目号 ITEM	零件号 P/N	数量 QTY	名称	DESCRIPTION
30	N010091	4	圆头方颈螺栓-M8x20-镀锌	SCREW M8x20 ZINC
31	N020001	5	自锁螺母-M8-镀锌	LOCK NUT M8 ZINC
32	N010014	2	圆头方径螺栓-M8x25-镀锌	SCREW M8x25 ZINC
33	N110004	1	万向轮 D100	UNIVERSAL WHEEL Φ 100
34	N010027	2	外六角-M3x20-不锈钢	SCREW M3x20 A2
35	A030005	1	脚踏限位挡板 109x33	GUARD 109x33
36	N030019	4	平垫-3x7x0.5-不锈钢	WASHER 3x7x0.5 A2
37	W020259	1	防水微动开关组件	MICROSWITCH ASSEMBLY NORMALLY SWITCH OFF
38	N020045	2	自锁螺母-M3-不锈钢	LOCK NUT M3 A2
39	C030006	1	脚踏垫 98x80	RUBBER PAD 98x80
40	N040003	1	弹垫-M10-镀锌	LOCK WASHER M10 ZINC
41	N010060	1	外六角-M10x25-镀锌	SCREW M10x25 ZINC
42	A050019	1	脚踏板 T70	PEDAL T70
43	B020004	1	铜套 8.3x15x18.5	BUSHING 8.3x15x18.5
44	N070001	4	轴承 6004	BEARING 6004
45	B060027	2	轴承垫圈 20x25x21	WASHER 20x25x21
46	B060028	2	垫圈 20x40x11	WASHER 20x40x11
47	C020004	2	驱动轮 D200x50	DRIVING WHEEL Φ 200x50
59	N010034	1	外六角-M8x20-镀锌	SCREW M8x20 ZINC

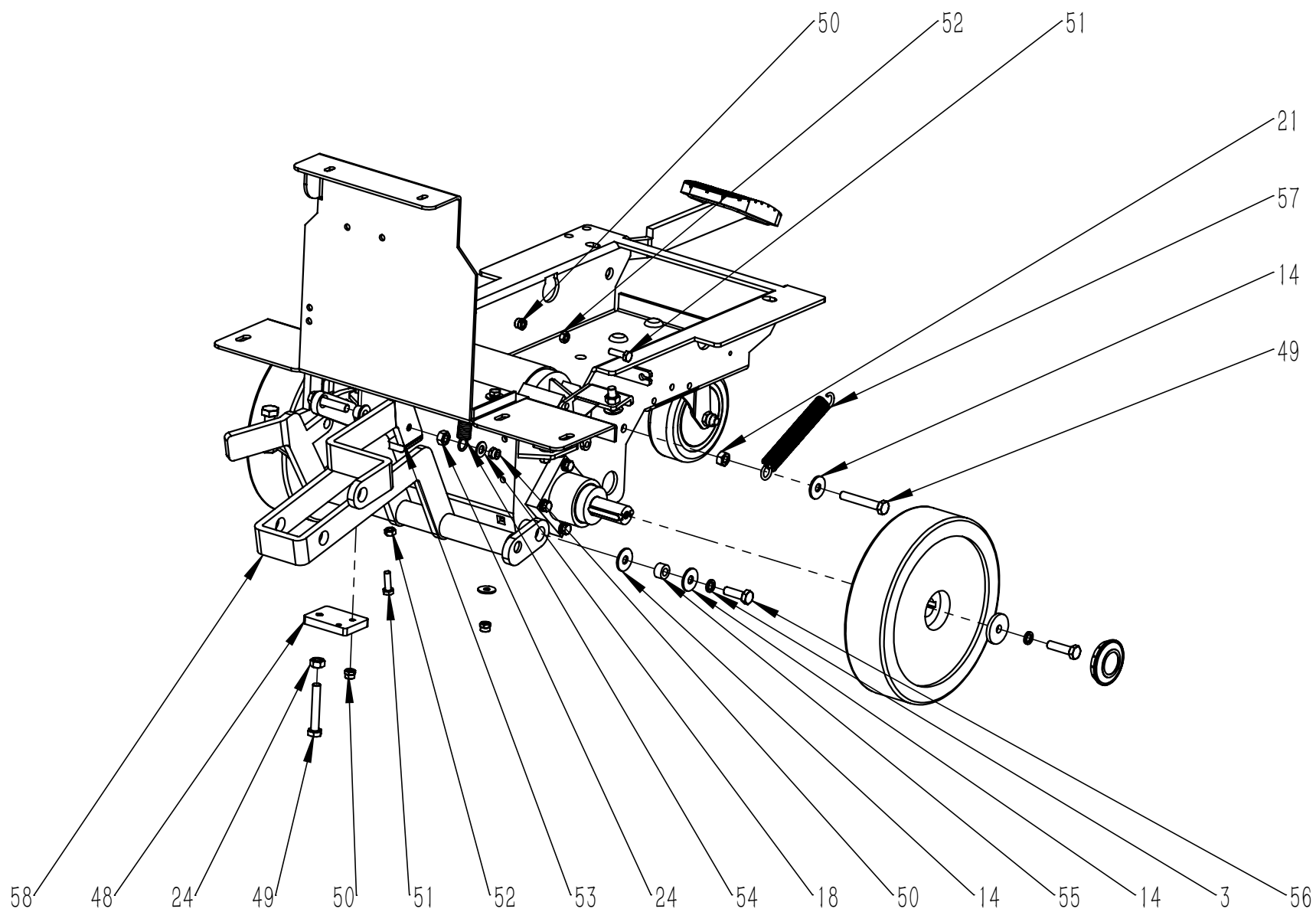

项目号 ITEM	零件号 P/N	数量 QTY	名称	DESCRIPTION
48	A030004	1	连接板 55x40	PLAQUE 55x40
49	N010010	2	外六角-M8x50-镀锌	SCREW M8x50 ZINC
50	N020012	4	自锁螺母-M6-镀锌	LOCK NUT M6 ZINC
51	N010006	3	外六角-M6x20-镀锌	SCREW M6x20 ZINC
52	N020022	2	螺母-M6-镀锌	NUT M6 ZINC
53	A040066	1	机头连接臂上	CONNECTING ARM OF MACHINE HEAD
54	B060030	1	机头拉簧 2x15x60	SPRING 2x15x60
55	B020001	1	铜套 8x15x8.5	BUSHING 8x15x8.5
56	N010007	1	外六角-M8x25-镀锌	SCREW M8x25 ZINC
57	B070003	1	拉簧 2.8x20x93	SPRING 2.8x20x93
58	A040064	1	机头连接臂	NOSE CONNECTING ARM

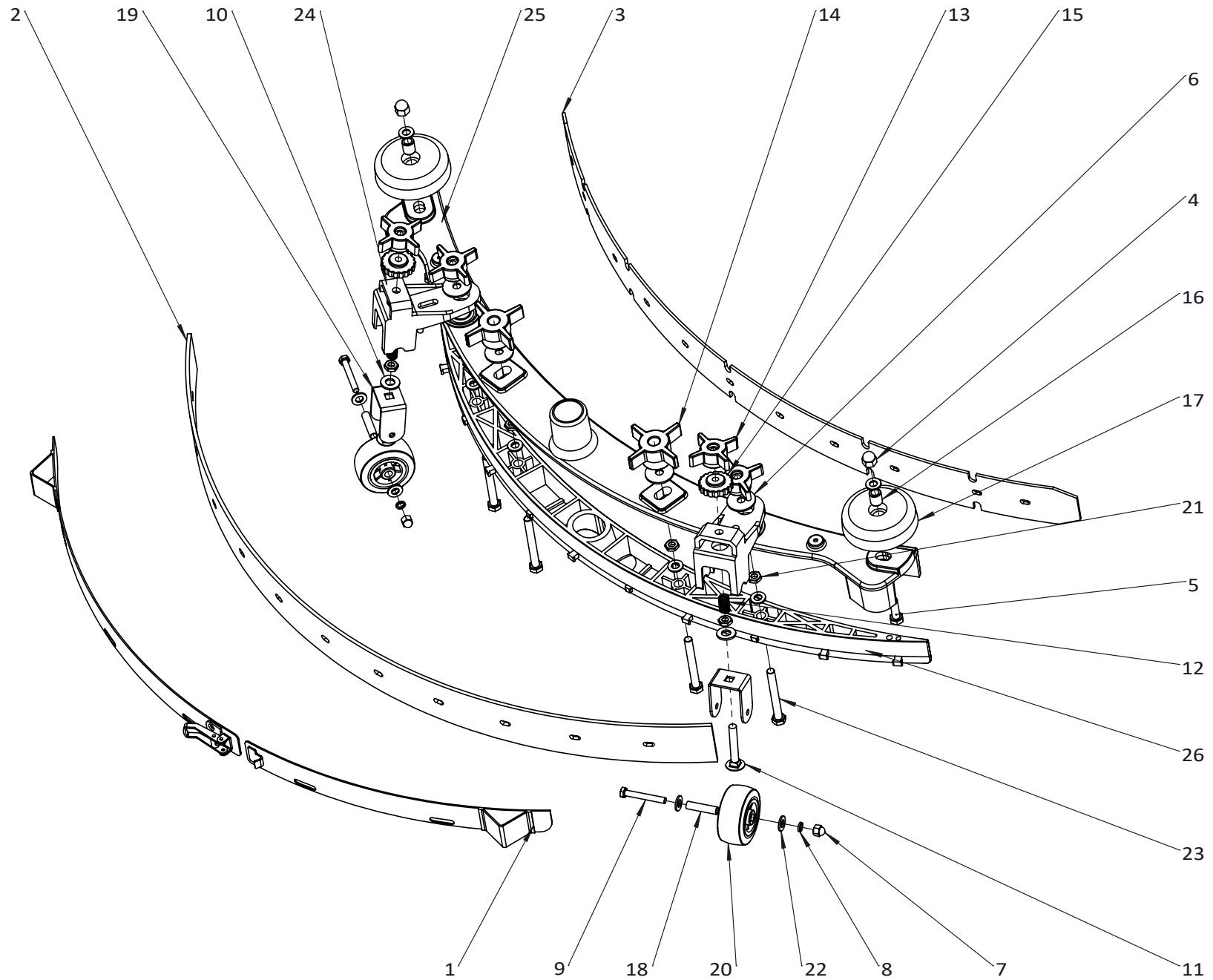

项目号 ITEM	零件号 P/N	数量 QTY	名称	DESCRIPTION
1	A300008	1	扒头后钢条-860-YS	PLATES 860 YS
2	C030139LAT	1	后刮条-860-YS	REAR SQUEEGE BLADE RUBBER 860 YS LATEX
3	C030140LAT	1	前刮条-860-YS	FRONT SQUEEGE BLADE RUBBER 860 YS LATEX
4	N020082	2	圆头盖形螺母-M8-不锈钢	ROUND HEAD CAP NUT M8 A2
5	N010094	2	外六角-M8x25-不锈钢	SCREW M8x25 A2
6	N030090	4	大平垫-8x30x2-不锈钢	WASHER 8x30x2 A2
7	N020013	2	圆头螺母-M6-不锈钢	ROUND HEAD CAP NUT M6 A2
8	N040001	2	弹垫-M6-镀锌	LOCK WASHER M6 ZINC
9	N010114	2	外六角-M6x45-镀锌	SCREW M6x45 ZINC
10	N030051	2	平垫-10x20x2-不锈钢	WASHER 10x20x2 A2
11	N010415	2	大圆头方颈螺栓-M8x50-不锈钢	SQUARE NECK BOLT M8x50 A2
12	B090020	2	压簧 D12XD10X19	SPRING D12XD10X19
13	N020083	4	四星螺母-M8X58-黄色-YS	NUT M8X58 YELLOW YS
14	N020084	2	四星螺母-M8X69-黄色-YS	NUT M8X69 YELLOW YS
15	N020085	2	花形螺母-M8X36-黄色-YS	NUT M8X69 YELLOW YS
16	B010107	2	防撞轮隔套 D12. 5XD8X14	SPACER D12.5XD8X14
17	R030007	2	防撞轮 D80X22	WHEEL D80X22
18	B010108	2	定向轮轴套 D8XD6. 5X33. 5	SPACER D8XD6.5X33.5
19	A250011	2	定向轮下支架	WHEEL SUPPORT DOWN
20	R030006	2	定向轮 D62X31	WHEEL D62X31
21	N020043	6	薄螺母-M8-不锈钢	NUT M8 A2
22	N030010	10	平垫-8x16x1. 6-不锈钢	WASHER 8x16x1.6 A2
23	N010127	4	外六角-M8x70-不锈钢-全牙	SCREW M8x70 A2
24	A250013	2	定向轮上支架	WHEEL SUPPORT UP
25	D010056	1	扒头主体-860-YS	SQUEEGEE BODY 860 YS
26	B080032	1	半月板-860-YS	PLATE 860 YS

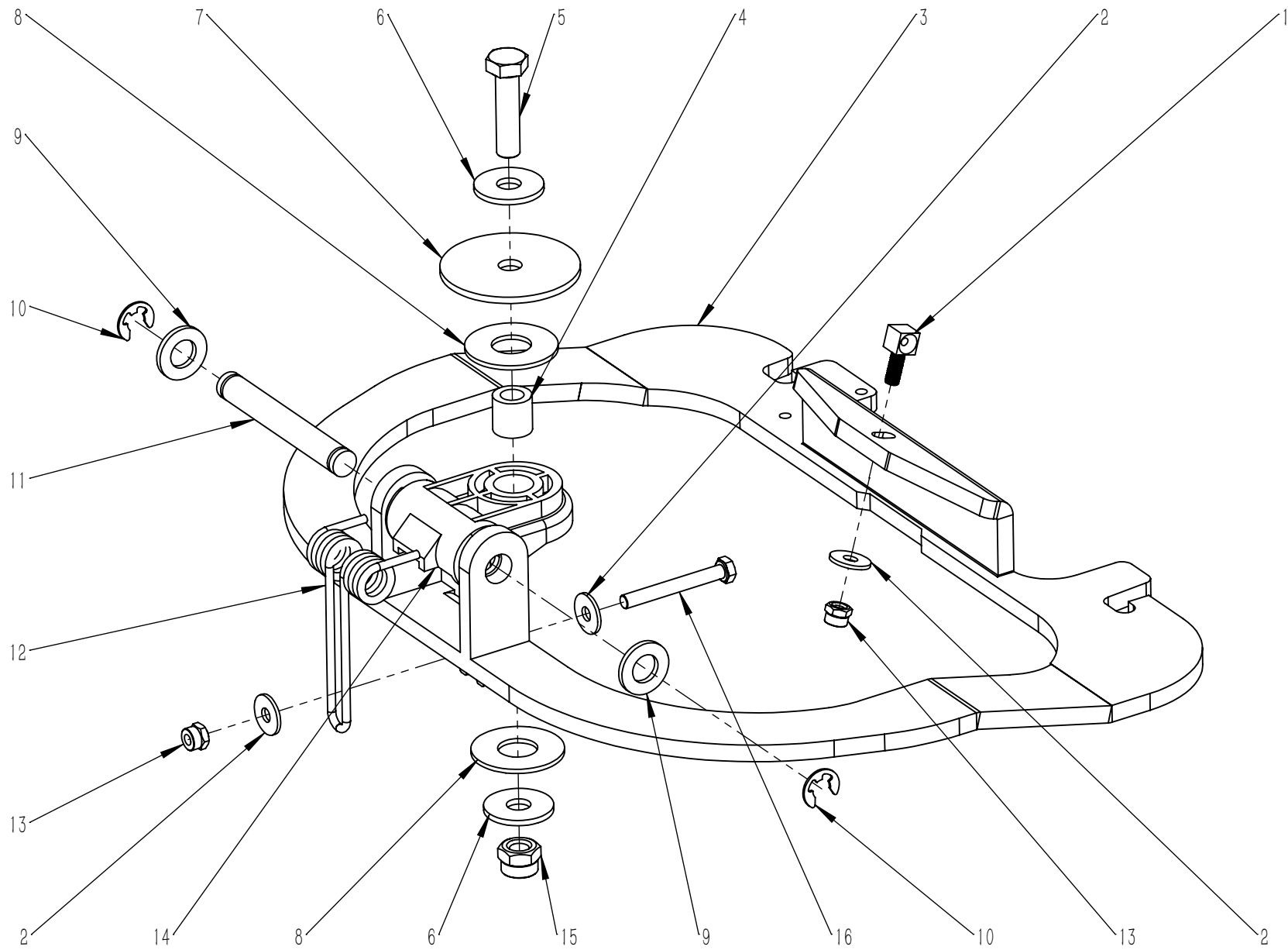

项目号 ITEM	零件号 P/N	数量 QTY	名称	DESCRIPTION
1	B060035	1	方头带孔螺栓-M6x25-镀锌	COUPLING M6x25 ZINC
2	N030008	3	平垫 6x18x1.6 镀锌	WASHER 6x18x1.6 ZINC
3	A050051	1	扒头支架 263	SUPPORT 263
4	B020003	1	铜套 10.2x17x16.5	BUSHING 10.2x17x16.5
5	N010026	1	外六角 M10x40 镀锌	SCREW M10x40 ZINC
6	N030041	2	平垫-10x30x2.5-镀锌	WASHER 10x30x2.5 ZINC
7	B050022	1	四氟垫片 10.2x60x3	WASHER 10.2x60x3
8	B050005	2	四氟垫片 17.2x40x2	WASHER 17.2x40x2
9	N030011	2	平垫 12x24x2.5 镀锌	WASHER 12x24x2.5 ZINC
10	N080005	2	卡簧 ϕ 9	CIRCLIP ϕ 9
11	B060099	1	转动轴 Φ 12x86	AXIS OF ROTATION Φ 12x86
12	B070016	1	压力弹簧 3.5x20x40.5	PRESSURE SPRING 3.5x20x40.5
13	N020012	2	自锁螺母 M6 镀锌	LOCK NUT M6 ZINC
14	D010007	1	转换座 58	COUPLING 58
15	N020002	1	自锁螺母 M10 镀锌	LOCK NUT M10 ZINC
16	N010021	1	外六角-M6x50-镀锌-全牙	SCREW M6x50 ZINC

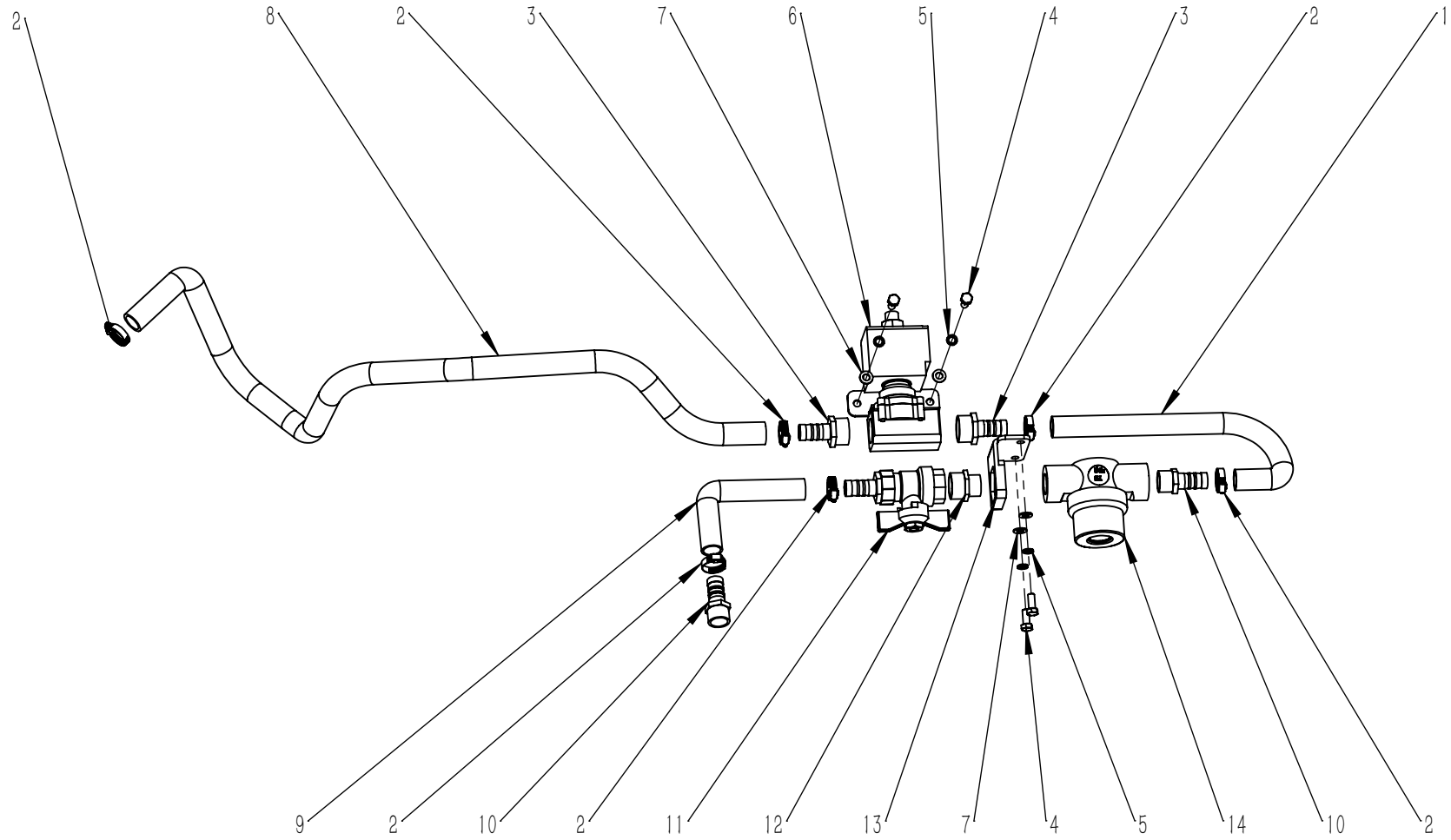

项目号 ITEM	零件号 P/N	数量 QTY	名称	DESCRIPTION
1	F050094.2	1	内嵌钢丝水管 D=18 D=13 L=250	PVC STEEL WIRE PIPE D=18 D=13 L=250
2	F050003	6	卡箍 Φ 10-16	SCREW CLAMP Φ 10-16
3	F020002	2	快速接头 1/2	CONNECTOR 1/2
4	N010208	4	外六角-M5x12-不锈钢	SCREW M5x12 A2
5	N040023	4	弹垫-M5-不锈钢	LOCK WASHER M5
6	W020256	1	电磁阀组件2-T55-70BT	SOLENOID VALVE ASSEMBLY T55/70BT
7	N030016	4	平垫 5x10x1 不锈钢	WASHER 5x10x1
8	F050094.3	1	内嵌钢丝水管 D=18 D=13 L=600	PVC STEEL WIRE PIPE D=18 D=13 L= 600
9	F050094.4	1	内嵌钢丝水管 D=18 D=13 L= 100	PVC STEEL WIRE PIPE D=18 D=13 L= 100
10	F020003	2	快速接头 3/8 D=12 d=10	CONNECTOR 3/8 D=12 d=10
11	F010006	1	蝶形球阀 1/2 直接头 D=10	BALL VALVE 1/2 CONNECTION STRAIGHT D=10
12	F020019	1	外丝接头 1/2-3/8 不锈钢	CONNECTOR 1/2-3/8 A2
13	A030034	1	球阀支架 35x43	SUPPORT 35x43
14	F010004	1	过滤器 3/8	FILTER 3/8

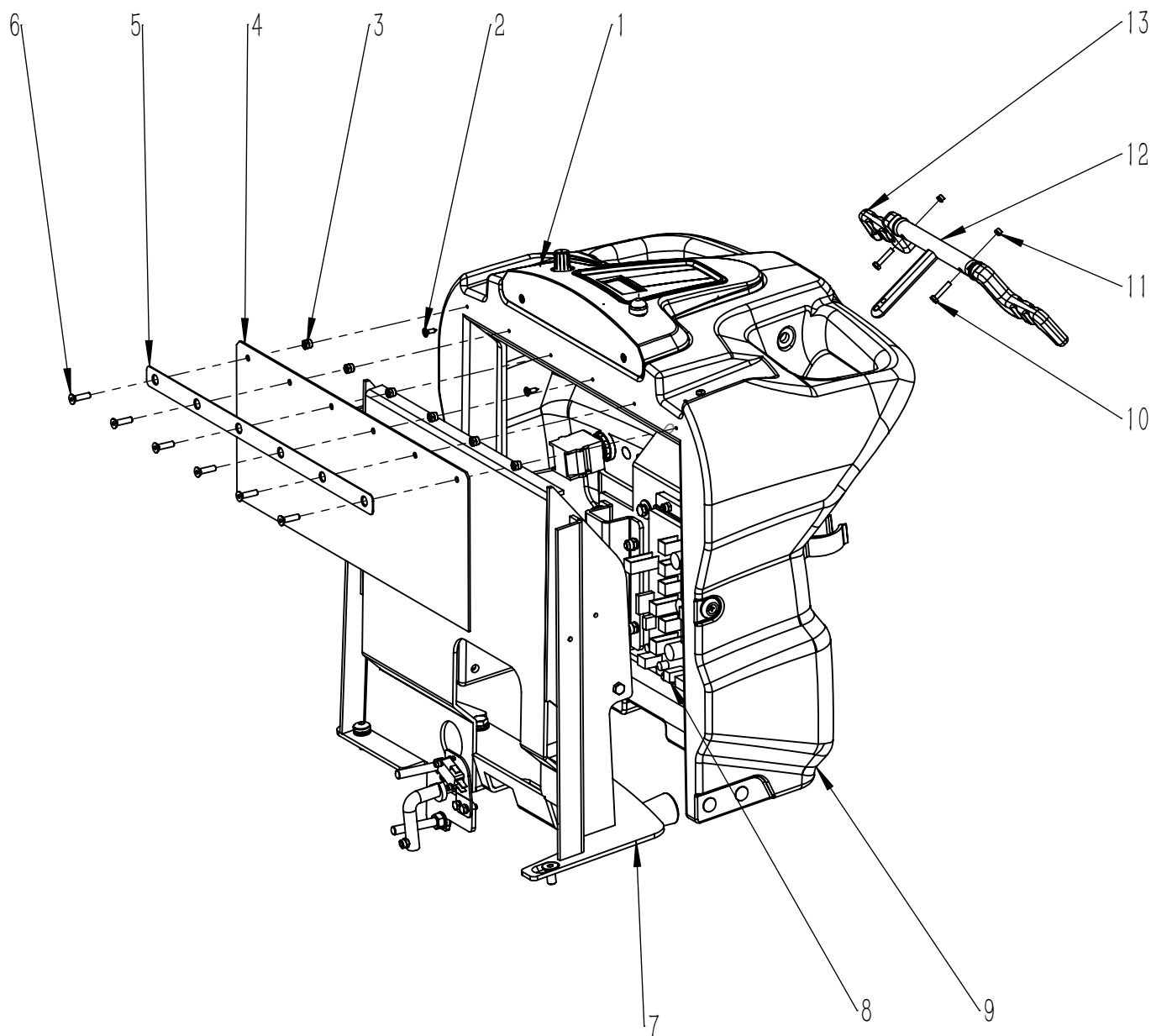

项目号 ITEM	零件号 P/N	数量 QTY	名称	DESCRIPTION
1	W010006	1	控制面板组件-T55BT-70BT	CONTROL PANEL ASSEMBLY T55BT/70BT
2	N010111	2	沉头十字自攻-3.5x13-不锈钢	SELF TAPPING SCREW 3.5x13 A2
3	N020016	6	自锁螺母-M5-镀锌	LOCK NUT M5 ZINC
4	B050027	1	手柄盒挡板 T70	BAFFLE T70
5	A060004	1	手柄盒橡胶压条 400x20	LAYERING 400x20
6	N010118	6	沉头内六角 M5X20-镀锌	SCREW M5x20 ZINC
7	A020002	1	手柄盒支架 T70	SUPPORT T70
8	W010155	1	电路板支架组件 T55BT	CIRCUIT BOARD SUPPORT ASEMBLY T55BT
9	C010004	1	手柄盒	HANDLE BAR
10	N010027	4	外六角-M3x20-不锈钢	SCREW M3x20 A2
11	N020045	4	自锁螺母-M3-不锈钢	LOCK NUT M3 A2
12	C020017	1	操控连接杆	ROCKER ARM
13	C020015	2	右操控把手	RIGHT LEVER

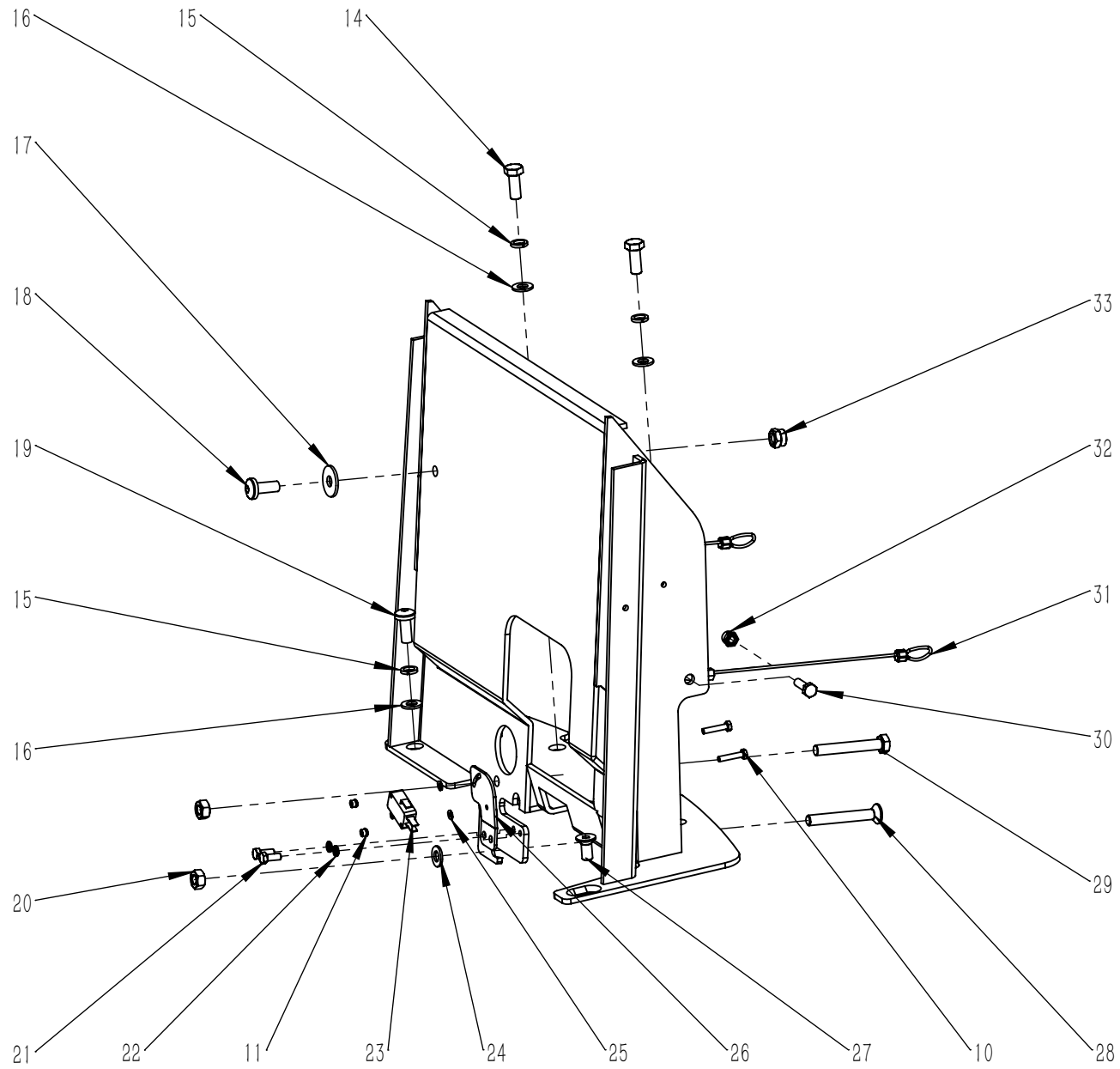

项目号 ITEM	零件号 P/N	数量 QTY	名称	DESCRIPTION
14	N010034	2	外六角-M8x20-镀锌	SCREW M8x20 ZINC
15	N040013	3	弹垫-M8-镀锌	LOCK WASHER M8 ZINC
16	N030006	3	平垫-8x16x1.6-镀锌	WASHER 8x16x1.6 ZINC
17	N030028	1	平垫-8x24x2-不锈钢	WASHER 8x24x2 A2
18	N010059	1	圆头内六角-M8x20-不锈钢	SCREW M8x20 A2
19	N010209	1	圆头内六角-M8x20-镀锌	SPECIAL SCREW M8x20 ZINC
20	N020010	2	螺母-M8-不锈钢	NUT M8 A2
21	N010024	2	外六角-M5x12-镀锌	SCREW M5x12 ZINC
22	N040007	2	弹垫-M5-镀锌	LOCK WASHER M5 ZINC
23	E020030	1	防水微动开关-250V-16A-常闭	MICROSWITCH 250V 16A NORMALLY SWITCH OFF
24	N030010	1	平垫-8x16x1.6-不锈钢	WASHER 8x16x1.6 A2
25	N030019	4	平垫-3x7x0.5-不锈钢	WASHER 3x7x0.5 A2
26	A050006	1	开关支架 R25	SUPPORT R25
27	N010019	1	沉头内六角-M8x18-镀锌	SCREW M8x18 ZINC
28	N010074	1	沉头内六角-M8×60-不锈钢	SCREW M8x60 A2
29	N010131	1	外六角-M8x55-不锈钢	SCREW M8x55 A2
30	N010006	2	外六角-M6x20-镀锌	SCREW M6x20 ZINC
31	B060033	2	手柄盒拉线 L=210	CABLE L=210
32	N020012	2	自锁螺母-M6-镀锌	LOCK NUT M6 ZINC
33	N020024	1	自锁螺母-M8-不锈钢	LOCK NUT M8 A2

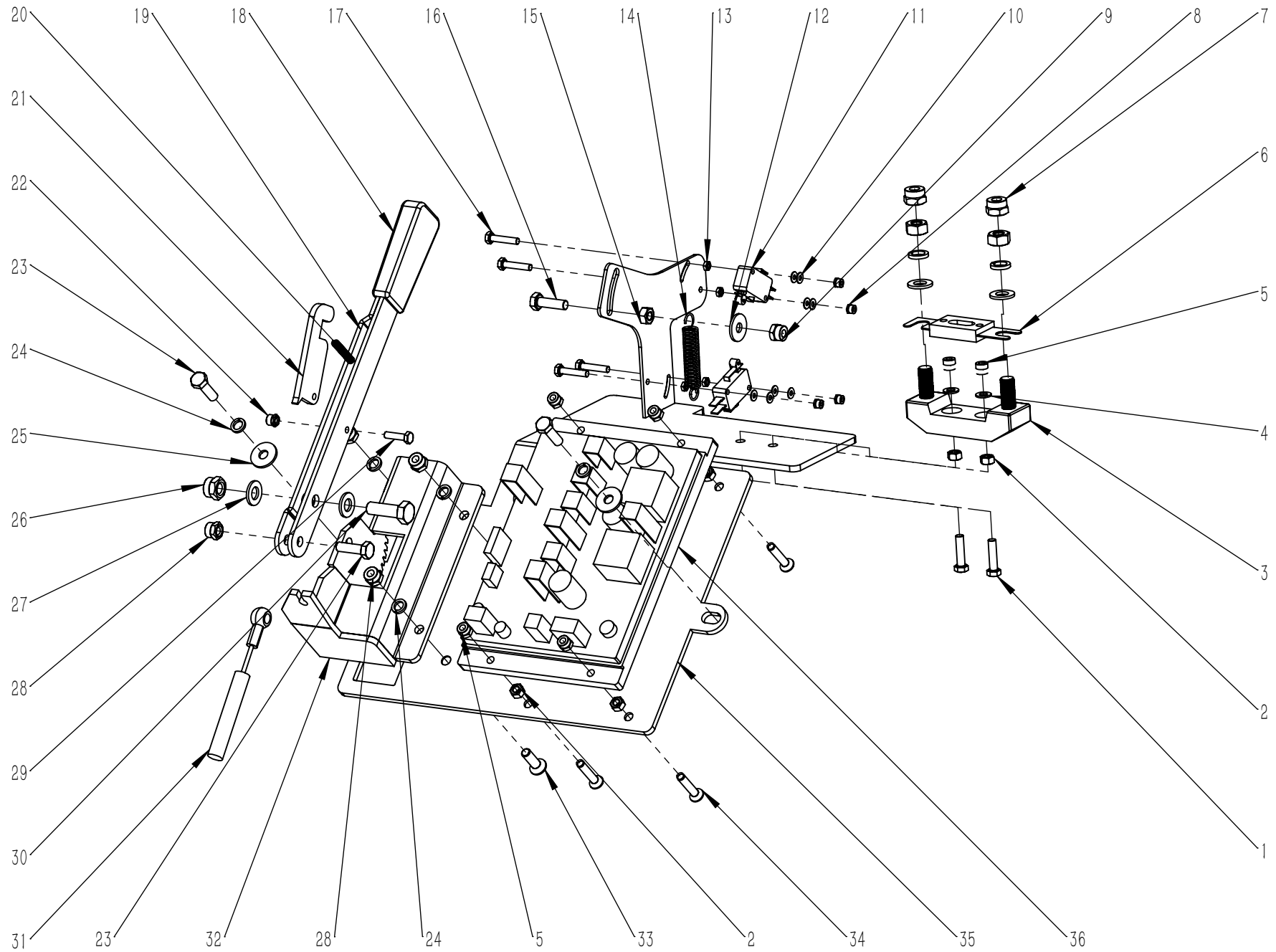

项目号 ITEM	零件号 P/N	数量 QTY	名称	DESCRIPTION
1	N010135	2	外六角-M5x20-不锈钢	SCREW M5x20 A2
2	N020046	6	螺母-M5-不锈钢	NUT M5 A2
3	E050004	1	保险座 80A	FUSE HOLDER 80A
4	N030016	2	平垫-5x10x1-不锈钢	WASHER 5x10x1
5	N020037	6	自锁螺母-M5-不锈钢	LOCK NUT M5 A2
6	E050005	1	保险 80A	FUSE 80A
7	N020024	2	自锁螺母-M8-不锈钢	LOCK NUT M8 A2
8	N020045	4	自锁螺母-M3-不锈钢	LOCK NUT M3 A2
9	N020006	1	自锁螺母-M6-不锈钢	LOCK NUT M6 A2
10	N030019	8	平垫-3x7x0.5-不锈钢	WASHER 3x7x0.5 A2
11	W020262	2	防水微动开关组件-250V-16A-常开	MICROSWITCH ASSEMBLY NORMALLY SWITCH ON
12	N030022	1	平垫-6x18x1.6-不锈钢	WASHER 6x18x1.6 A2
13	N020044	4	螺母-M3-不锈钢	NUT M3 A2
14	B070011	1	弹簧 0.8x10x55	SPRING 0.8x10x55
15	N020005	1	螺母-M6-不锈钢	NUT M6 A2
16	N010013	1	外六角-M6x20-不锈钢	SCREW M6x20 A2
17	N010027	4	外六角-M3x20-不锈钢	SCREW M3x20 A2
18	N090003	1	刹车手柄胶套 20x60	RUBBER SLEEVE 20x60
19	A020003	1	刹车手柄 240x20	BRAKE HANDLE 240x20
20	B060032	1	刹车压簧 0.5x5x25	SPRING 0.5x5x25
21	A050008	1	刹车锁 D4	BRAKE LOCK Φ4
22	N020042	1	自锁螺母-M4-不锈钢	LOCK NUT M4 A2
23	N010006	4	外六角-M6x20-镀锌	SCREW M6x20 ZINC
24	N040001	5	弹垫-M6-镀锌	LOCK WASHER M6 ZINC
25	N030008	3	平垫-6x18x1.6-镀锌	WASHER 6x18x1.6 ZINC
26	N020001	1	自锁螺母-M8-镀锌	LOCK NUT M8 ZINC
27	N030006	2	平垫-8x16x1.6-镀锌	WASHER 8x16x1.6 ZINC
28	N020012	4	自锁螺母-M6-镀锌	LOCK NUT M6 ZINC
29	N010028	1	外六角-M4x16-不锈钢	SCREW M4x16 A2
30	N010007	1	外六角-M8x25-镀锌	SCREW M8x25 ZINC

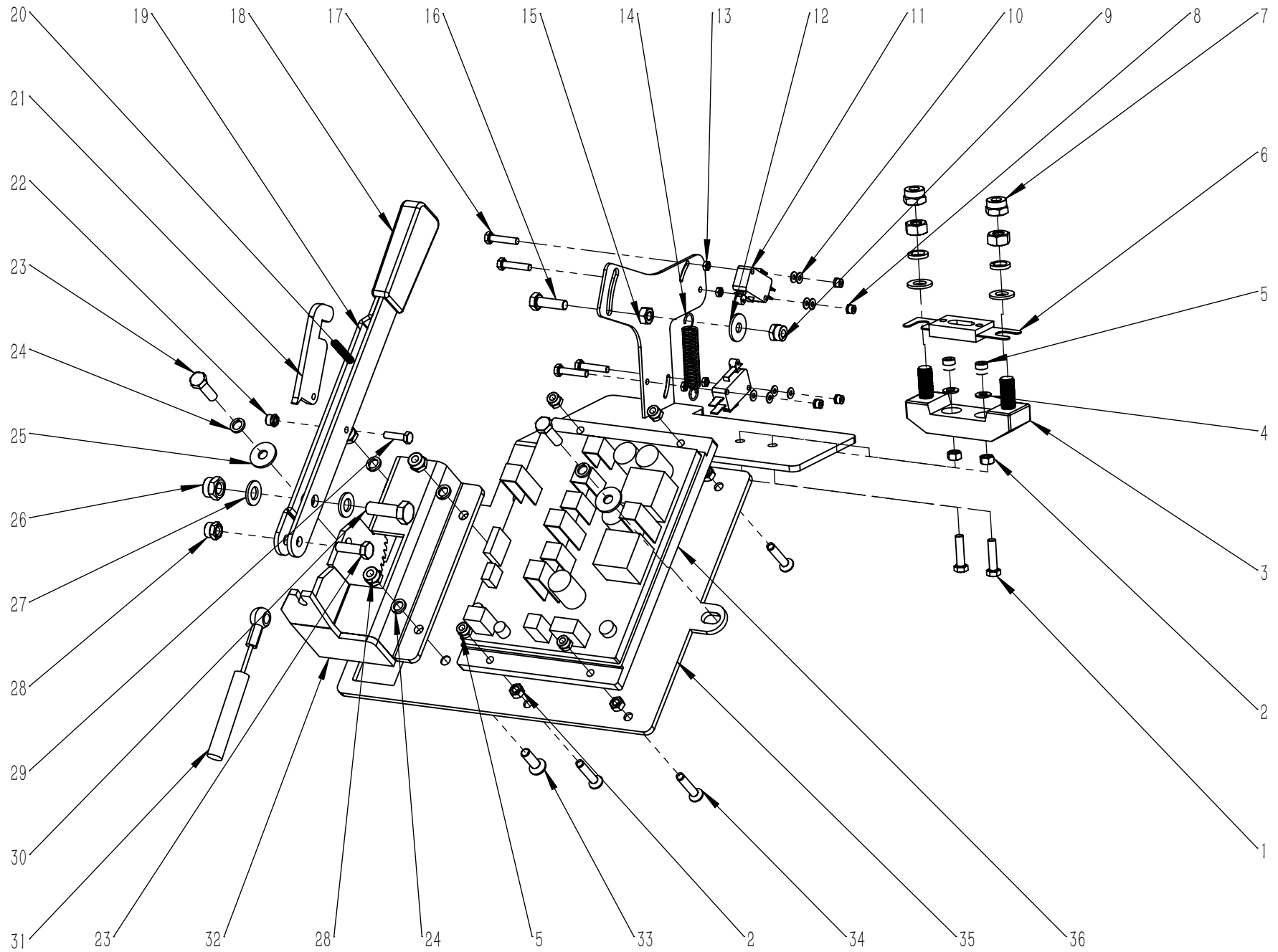

项目号 ITEM	零件号 P/N	数量 QTY	名称	DESCRIPTION
31	B060101	1	刹车线 L=1180	CABLE L=1180
32	A020004	1	刹车手柄支架 130x57.5	SUPPORT 130x57.5
33	N010016	3	沉头内六角-M6x20-不锈钢	SCREW M6x20 A2
34	N010066	4	沉头内六角-M5x25-不锈钢	SCREW M5x25 A2
35	A020046	1	电路板支架 KDS	CIRCUIT BOARD SUPPORT KDS
36	W020408	1	控制器组件-KDS-T55BT/70BT	CONTROLLER ASSEMBLY KDS T55BT/70BT

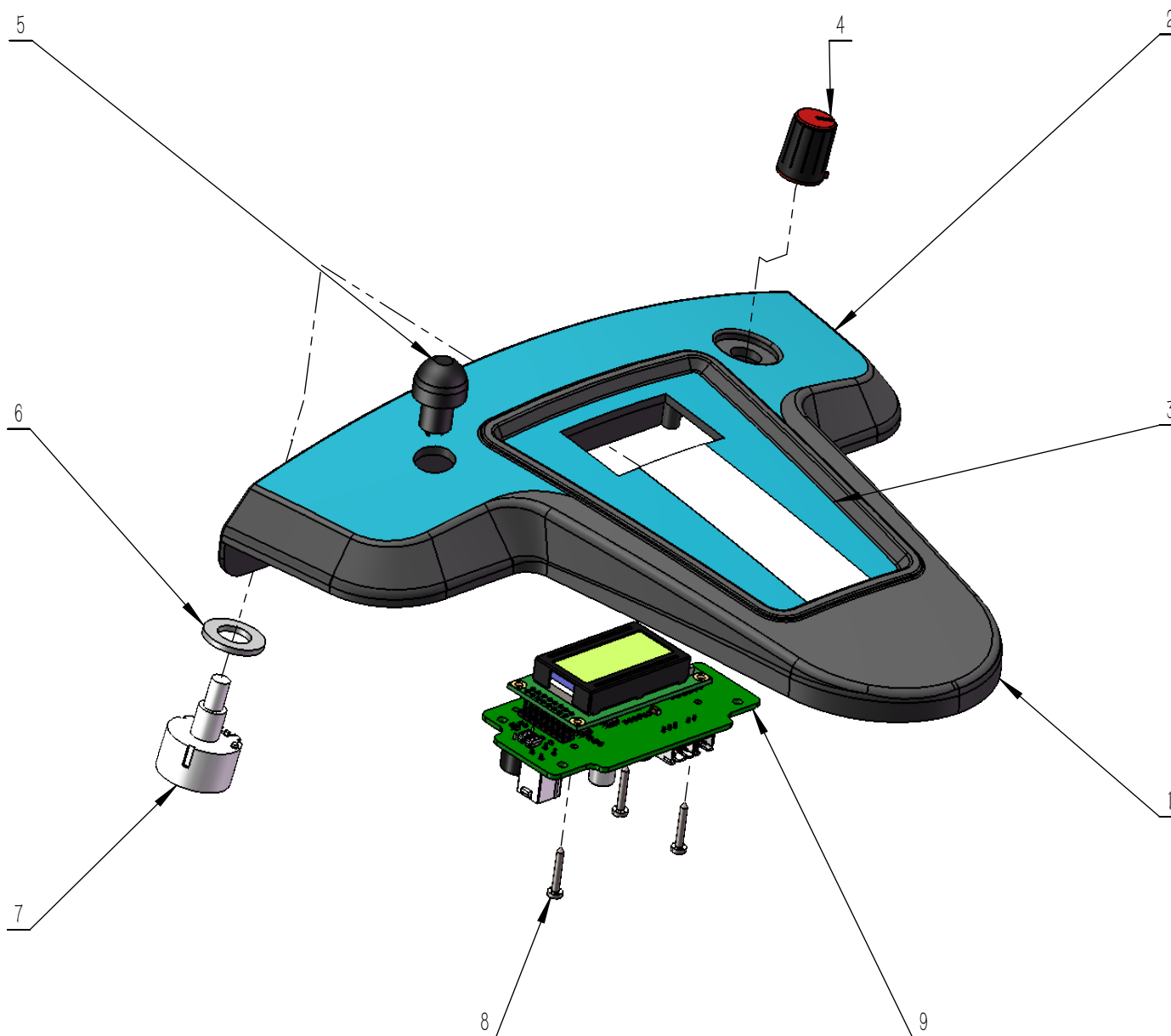

项目号 ITEM	零件号 P/N	数量 QTY	名称	DESCRIPTION
1	C020013	1	控制面板-T55-T70	CONTROL PANEL T55/70
2	C040001	1	控制面板标签 T55BT	CONTROL PANEL LABEL T55BT
3	C040002	1	控制面板标签 T55	CONTROL PANEL LABEL T55
4	E020009	1	调速开关旋帽	TURN CAP
5	W020258	1	选择按钮组件	BUTTON
6	N030004	1	平垫-10x20x2-镀锌	WAHSE 10x20x2 ZINC
7	W020264	1	调速开关组件	SPEED SWITCH ASSEMBLY
8	N010228	3	十字盘头自攻螺钉-ST2.2x16-不锈钢	SELF TAPPING SCREW ST2.2x16 A2
9	W020448	1	控制面板组件-KDS-T70BT-TVX	CONTROL PANEL ASSEMBLY KDS T70BT TVX

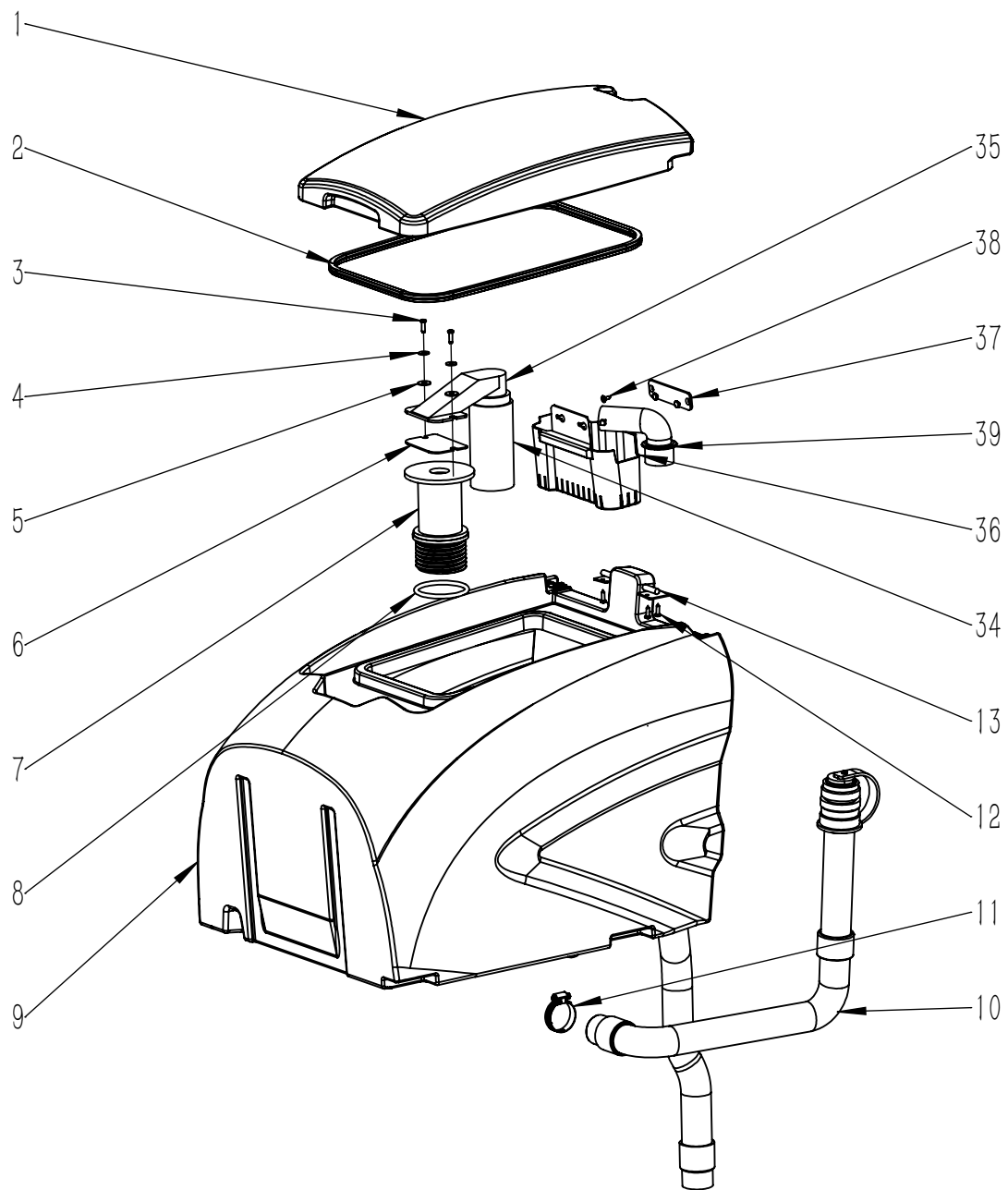

项目号 ITEM	零件号 P/N	数量 QTY	名称	DESCRIPTION
1	C010003	1	污水箱盖板	RECOVERY TANK COVER
2	N090010.1	1	污水箱上盖密封条 L=1280	RUBBER SEAL STRIP L=1280
3	N010251	2	十字盘头自攻螺钉-ST4.8x16-不锈钢	SCREW ST4.8x16 A2
4	N030040	5	平垫-5x15x1.2-不锈钢	WASHER 5x15x1.2
5	N030022	2	平垫-6x18x1.6-不锈钢	WASHER 6x18x1.6 A2
6	C030040	1	吸水口密封垫 T35	SUCTION GASKET T35
7	C020283	1	浮球安装座	FLOAT MOUNT
8	N090042	1	O 型密封圈 内径 D67x 线径 D6	O RING Φ 67x Φ 6
9	C010002	1	污水箱 70L	RECOVERY TANK 70L
10	F060001	1	排污管 D38x1040	DRAINAGE PIPE D38x1040
11	F050006	2	卡箍 D33-57	SCREW CLAMP Φ 33-57
12	N010052	8	圆头十字自攻螺丝-M4.2x16-不锈钢	SELF TAPPING SCREW M4.2x16 A2
13	A010001	2	箱盖固定板 34x30	PLAQUE 34x30
34	F040010	1	吸水口浮球 T35	SEWAGE TANK FLOAT FILTER
35	C020049	1	吸水口主体 T35	SUCTION BODY T35
36	C020087	1	一级过滤器 T130	PRIMARY FILTER T130
37	A040107	1	过滤篮固定座	FILTER BASKET HOLDER
38	N010097	2	沉头十字自攻螺栓-M4.2x13-不锈钢	SELF TAPPING SCREW M4.2x13 A2
39	C020008	1	污水进水口弯头 D.38	CONNECTOR BEND D.38

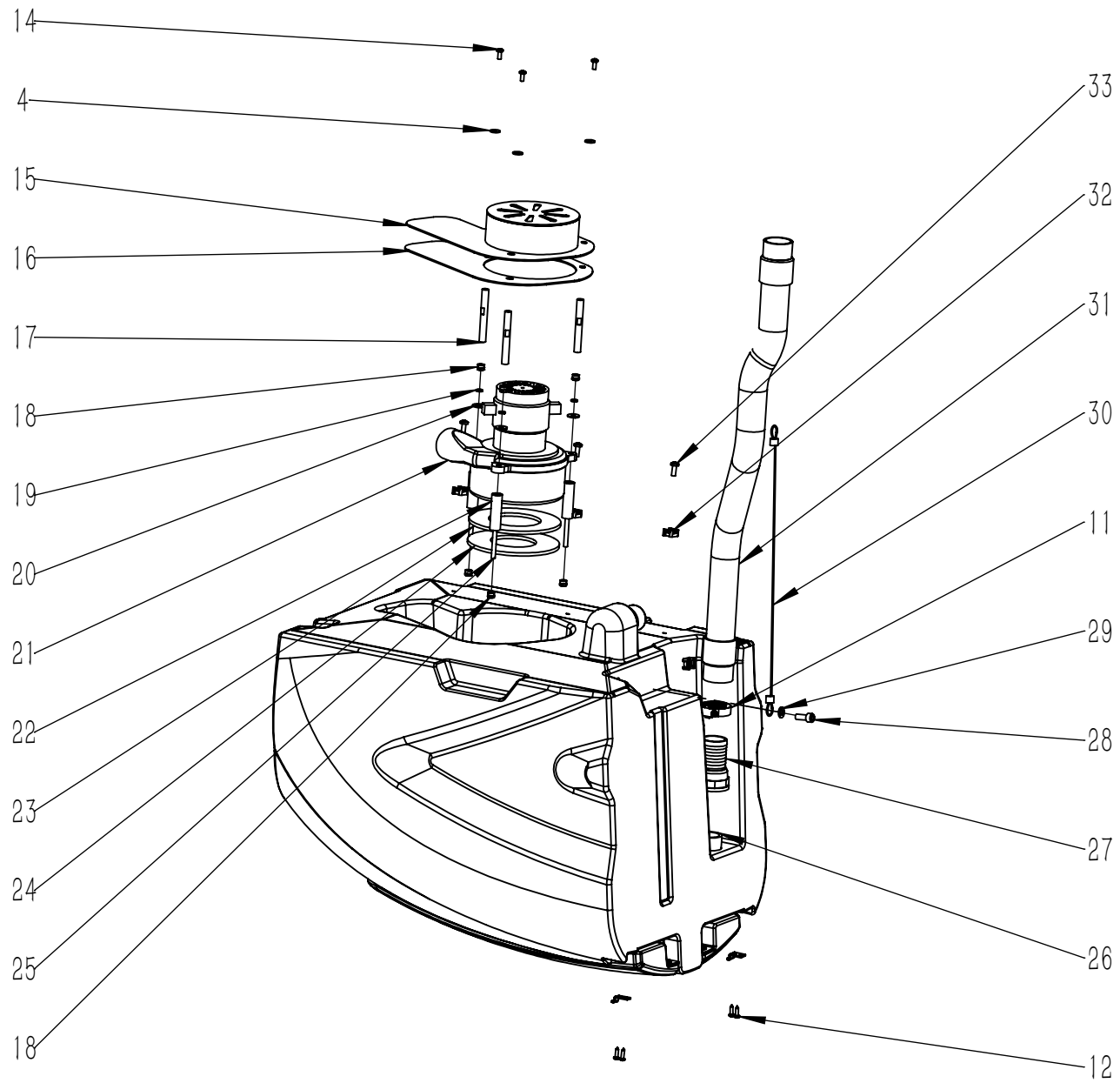

项目号 ITEM	零件号 P/N	数量 QTY	名称	DESCRIPTION
14	N010112	3	盘头十字-M5x16-不锈钢	SCREW M5x16 A2
15	A040083	1	消音盖板 T55	MUFFLER COVER T55
16	C020105	1	消音棉 T55	SOUNDPROOF COTTON T45
17	B020035	3	铜螺柱 L=82	COPPER STUD L=82
18	N020012	6	自锁螺母-M6-镀锌	LOCK NUT M6 ZINC
19	N040001	3	弹垫-M6-镀锌	LOCK WASHER M6 ZINC
20	N030008	3	平垫-6x18x1.6-镀锌	WASHER 6x18x1.6 ZINC
21	W020252	1	吸水电机组件-24V-390W-JH	VACUUM MOTOR ASSEMBLY 24V 390W JH
22	B050029	3	支撑套管 55	SLEEVING 55
23	F040005	1	3M 背胶 Φ (140-70)	3M ADHESIVES GUM Φ (140-70)
24	F040001	1	吸水电机消音垫 D140x5	SPONGE Φ 140x5
25	N100008	3	螺杆 M6 \times 100	SCREW M6x100mm
26	C020008	1	污水进水口弯头 D.38	CONNECTOR BEND D.38
27	C020009	1	污水进水口直接头 D.38	CONNECTOR STRAIGHT D.38
28	B060084	1	水箱拉线 L= 345	CABLE L=345
29	N010059	1	圆头内六角-M8x20-不锈钢	SCREW M8x20 A2
30	N030028	1	平垫-8x24x2-不锈钢	WASHER 8x24x2 A2
31	F060005	1	吸污管 D38x1120	SUCTION HOSE D.38x1120
32	N090002	4	扎带固定座 23x16	SUPPORT 23x1
33	N010073	4	圆头十字螺丝-M5x16-镀锌	SCREW M5x16 ZINC

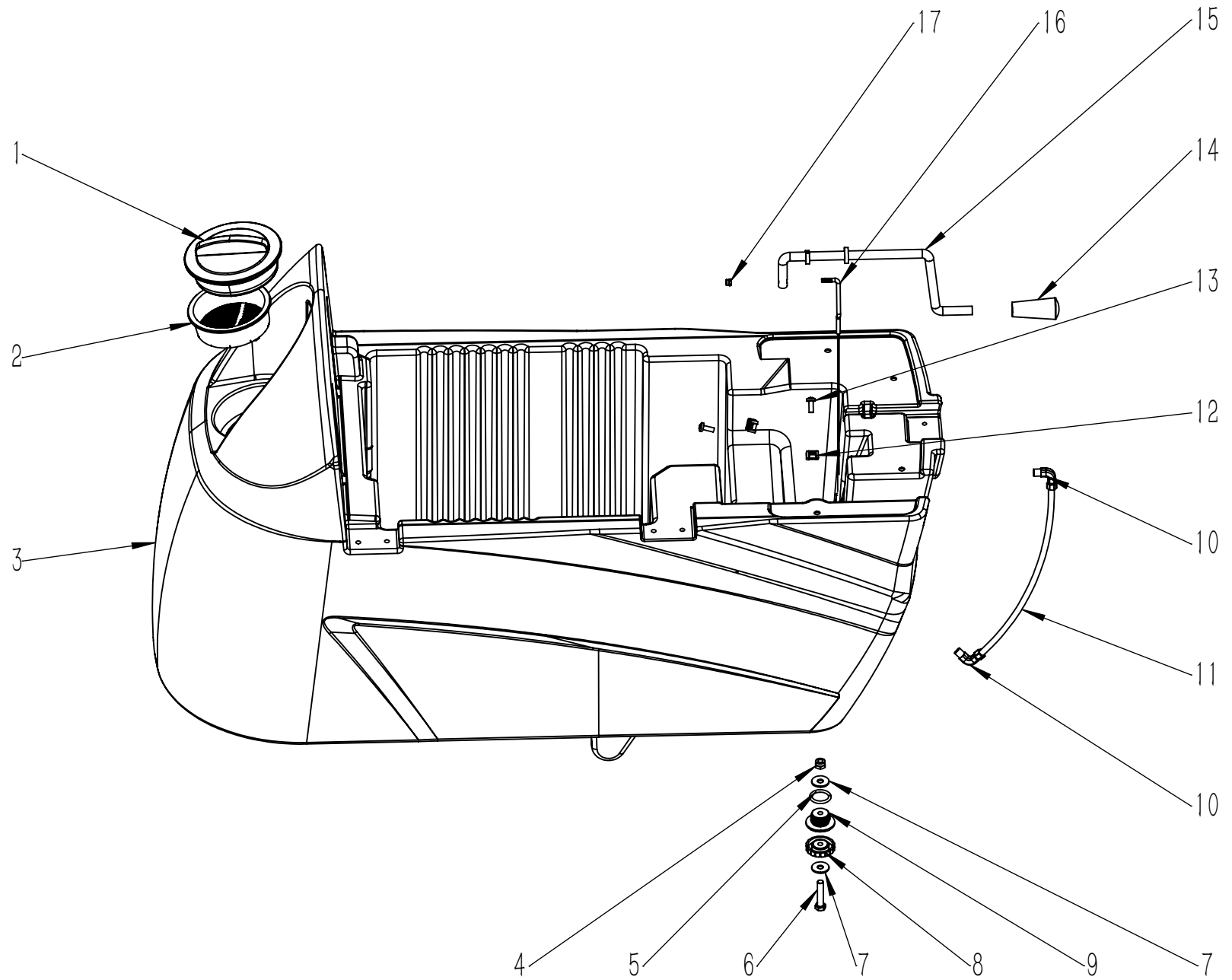

项目号 ITEM	零件号 P/N	数量 QTY	名称	DESCRIPTION
1	C020005	1	清水箱注水口盖子 D115	THREADED COVER Φ115
2	C020006	1	清水箱注水口滤网 D110	FILTER Φ110
3	C010001	1	清水箱 T70	SOLUTION TANK T70
4	N020024	1	自锁螺母-M8-不锈钢	LOCK NUT M8 A2
5	N090079	1	堵头胶圈外径 34 线径 5mm	PLUG APRON OUTER DIAMETER 34 WIRE DIAMETER 5mm
6	N010068	1	外六角-M8X40-不锈钢	SCREW M8x40 A2
7	N030028	2	平垫-8x24x2-不锈钢	WASHER 8x24x2 A2
8	N020009	1	花型螺母 M8	NUT M8
9	B020006	1	堵头 3/4 英寸	PLUG 3/4"
10	F020021	2	水位显示管安装头 M10	LIQUID LEVEL DISPLAY TUBE MOUNTING HEAD M10
11	F050032.2	1	PVC 水管 D=8, d=6,L=270	PVC WATER PIPE D=8,d=6,L=270
12	N090002	2	扎带固定座 23x16	SUPPORT 23x1
13	N010073	2	圆头十字螺丝-M5x16-镀锌	SCREW M5x16 ZINC
14	N100007	1	提升摇臂把手 M12	HANDLE M12
15	A050005	1	提升摇臂 T70	LEVER T70
16	B060110	1	扒头拉线 T70	CABLE T70
17	N020016	1	自锁螺母-M5-镀锌	LOCK NUT M5 ZINC

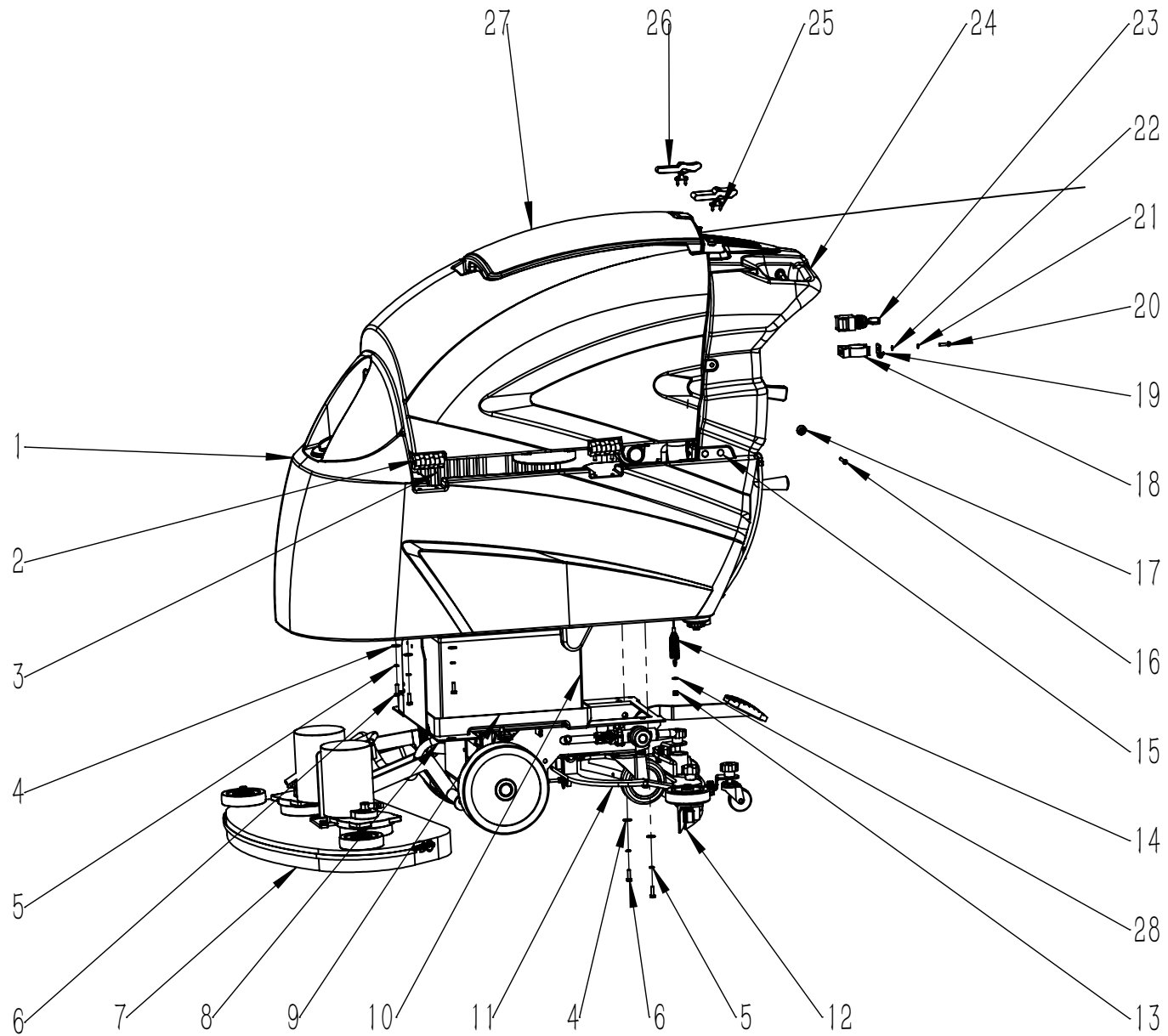

项目号 ITEM	零件号 P/N	数量 QTY	名称	DESCRIPTION
1	C010001	1	清水箱 T70	SOLUTION TANK T70
2	C020011	3	合页 40x14	HINGE 40x14
3	N010017	12	沉头内六角-M6x25-发黑	SCREW M6x25
4	N030008	6	平垫-6x18x1.6-镀锌	WASHER 6x18x1.6 ZINC
5	N040001	6	弹垫-M6-镀锌	LOCK WASHER M6 ZINC
6	N010006	6	外六角-M6x20-镀锌	SCREW M6x20 ZINC
7	W010250	1	机头组件-T70-双电机	NOSE ASSEMBLY T70(DOUBLE MOTOR)
8	W010002	1	底座架组件 T70BT	FRAME ASSEMBLY T70BT
9	C020010	1	电池座 370x364x45	BATTERY BASE 370x364x45
10	E040072	2	电池 AGM-12V-115Ah-2-中文	BATTERY 12V 115Ah AGM
11	W010063	1	扒头支架组件-T55-T70	SQUEEGEE SUPPORT ASSEMBLY T55/T70
12	W010831	1	扒头组件-860-YS	SQUEEGEE ASSEMBLY 860 YS
13	N020012	1	自锁螺母-M6-镀锌	LOCK NUT M6 ZINC
14	B070017	1	单向拉簧 3x20x75.4	SPRING 3x20x75.4
15	N090025	4	孔堵头 D8	PLUG Φ8
16	N010067	2	沉头十字-M5x45-不锈钢	SCREW M5x45 A2
17	C020028	2	异形垫片 D5	WASHER Φ5
18	C020014	1	管托 D43	SCREW CLAMP Φ43
19	A060023	1	排污管挂钩 T70	DRAINAGE PIPE POTHOOK T70
20	N010029	1	外六角-M5x16-不锈钢	SCREW M5x16 A2
21	N040023	1	弹垫-M5-不锈钢	LOCK WASHER M5
22	N030016	1	平垫-5x10x1-不锈钢	WASHER 5x10x1
23	W020013	1	钥匙开关组件 双开	KEY SWITCH ASSEMBLY
24	W010332	1	手柄盒组件-T70BT-KDS	HANDLE BOX ASSEMBLY T70BT KDS
25	N010052	4	圆头十字自攻螺丝-M4.2x16-不锈钢	SELF TAPPING SCREW M4.2x16 A2
26	N090004	2	橡胶搭扣 50	RUBBER HASP 50
27	W010169	1	污水箱组件 T70BT	RECOVERY TANK ASSEMBLY T70BT
28	N030007	1	平垫-6x12x1.6-镀锌	WASHER 6x12x1.6 ZINC

项目号 ITEM	零件号 P/N	数量 QTY	名称	DESCRIPTION
1	C040003	1	机器左侧标签 T45/T55/T70/90	LEFT LABEL T45/T55/T70/90
2	C040004	1	机器右侧标签 T45/T55/T70/90	RIGHT LABEL T45/T55/T70/90
3	M010007	1	纸箱 T70/T90 1440x760x1090	CARTON BOX 1440x760x1090
4	C040026	1	刹车标识	DECAL BRAKE
5	C040025	1	提升摇臂标识	LABELDECAL ROCKER ARM
6	P010004	1	保修卡	WARRANTY CARD
7	P010012	1	测试报告	TEST REPORT
8	W040704	1	包装组件 2 T70 (通用)	PACKING ASSEMBLY NO.2 T70
9	C030041	1	刷盘防溅条 87×1230	RUBBER SKIRT 87x1230
10	M010015	1	塑料包装袋 1400x700x1000	PLASTIC PACKAGE BAG 1400x700x1000
11	M020008	4	三角挡块 50x50x100	TRIANGLE BLOCK 50x50x100
12	M020010	1	木托盘 T70/90L 1440x760x120	PALLET T70/90L 1440x760x120
13	M010008	1	纸箱上盖-1460x800x100- T70	CARTON BOX COVER 1460x800x100
14	M010014	1	说明书自封袋 340x240mm	PLASTIC PACKAGE BAG 340x240mm
15	M020007	12	支撑护角 50x50x100	ANGLE BEAD 50x50x100
16	M020011	6	木条 T70/90 40*40*1070	BATTEN T70/90 40x40x1070
17	M010130	1	860扒头纸盒 880*225*135	SQUEEGEE CARTON BOX 860 880x225x135



项目号 ITEM	零件号 P/N	名称	数量 QTY	DESCRIPTION
1	C030162		1	RUBBER SKIRT T70
2	C030003		1	REAR SUPPORT PLATE 3X35X986
3	C030139PU		1	FRONT SQUEEGE BLADE RUBBER PU 860
4	C030140PU		1	REAR SQUEEGE BLADE RUBBER PU 860
5	N150002P		2	13" BRUSH 0.4
6	N150002		2	13" BRUSH PP0.6
7	N150007		2	13"WATERPROOF BRUSH PP0.5
12	N1500058		2	19" PAD HOLDER